



MX29LV320AT/B

32M-BIT [4M x 8 / 2M x 16] SINGLE VOLTAGE 3V ONLY FLASH MEMORY

FEATURES

GENERAL FEATURES

- 4,194,304 x 8 / 2,097,152 x 16 switchable
- Sector Structure
 - 8K-Byte x 8 and 64K-Byte x 63
- Extra 64K-Byte sector for security
 - Features factory locked and identifiable, and customer lockable
- Twenty-Four Sector Groups
 - Provides sector group protect function to prevent program or erase operation in the protected sector group
 - Provides chip unprotect function to allow code changing
 - Provides temporary sector group unprotect function for code changing in previously protected sector groups
- Single Power Supply Operation
 - 2.7 to 3.6 volt for read, erase, and program operations
- Latch-up protected to 250mA from -1V to Vcc + 1V
- Low Vcc write inhibit is equal to or less than 1.4V
- Compatible with JEDEC standard
 - Pinout and software compatible to single power supply Flash
- **2nd generation of 3V/32M Flash product**
 - **Fully compatible with MX29LV320T/B device**

PERFORMANCE

- High Performance
 - Fast access time: 70/90ns
 - Fast program time: 7us/word typical utilizing accelerate function
 - Fast erase time: 0.9s/sector, 35s/chip (typical)

GENERAL DESCRIPTION

The MX29LV320AT/B is a 32-mega bit Flash memory organized as 4M bytes of 8 bits and 2M words of 16 bits. MXIC's Flash memories offer the most cost-effective and reliable read/write non-volatile random access memory. The MX29LV320AT/B is packaged in 48-pin TSOP and 48-ball CSP. It is designed to be reprogrammed and erased in system or in standard EPROM programmers.

The standard MX29LV320AT/B offers access time as fast as 70ns, allowing operation of high-speed microprocessors without wait states. To eliminate bus contention, the MX29LV320AT/B has separate chip enable (CE) and output enable (OE) controls.

- Low Power Consumption
 - Low active read current: 10mA (typical) at 5MHz
 - Low standby current: 200nA (typical)
- Minimum 100,000 erase/program cycle
- 10 years data retention

SOFTWARE FEATURES

- Erase Suspend/ Erase Resume
 - Suspends sector erase operation to read data from or program data to another sector which is not being erased
- Status Reply
 - Data polling & Toggle bits provide detection of program and erase operation completion
- Support Common Flash Interface (CFI)

HARDWARE FEATURES

- Ready/Busy (RY/BY) Output
 - Provides a hardware method of detecting program and erase operation completion
- Hardware Reset (RESET) Input
 - Provides a hardware method to reset the internal state machine to read mode
- WP/ACC input pin
 - Provides accelerated program capability

PACKAGE

- 48-Pin TSOP
- 48-Ball CSP

MXIC's Flash memories augment EPROM functionality with in-circuit electrical erasure and programming. The MX29LV320AT/B uses a command register to manage this functionality.

MXIC Flash technology reliably stores memory contents even after 100,000 erase and program cycles. The MXIC cell is designed to optimize the erase and program mechanisms. In addition, the combination of advanced tunnel oxide processing and low internal electric fields for erase and programming operations produces reliable cycling.

The MX29LV320AT/B uses a 2.7V to 3.6V VCC supply to perform the High Reliability Erase and auto Program/Erase algorithms.

The highest degree of latch-up protection is achieved with MXIC's proprietary non-epi process. Latch-up protection is proved for stresses up to 100 milliamperes on address and data pin from -1V to VCC + 1V.

AUTOMATIC PROGRAMMING

The MX29LV320AT/B is byte/word programmable using the Automatic Programming algorithm. The Automatic Programming algorithm makes the external system do not need to have time out sequence nor to verify the data programmed. The typical chip programming time at room temperature of the MX29LV320AT/B is less than 36 seconds.

AUTOMATIC PROGRAMMING ALGORITHM

MXIC's Automatic Programming algorithm require the user to only write program set-up commands (including 2 unlock write cycle and AOH) and a program command (program data and address). The device automatically times the programming pulse width, provides the program verification, and counts the number of sequences. A status bit similar to DATA polling and a status bit toggling between consecutive read cycles, provide feedback to the user as to the status of the programming operation.

AUTOMATIC CHIP ERASE

The entire chip is bulk erased using 50 ms erase pulses according to MXIC's Automatic Chip Erase algorithm. Typical erasure at room temperature is accomplished in less than 35 seconds. The Automatic Erase algorithm automatically programs the entire array prior to electrical erase. The timing and verification of electrical erase are controlled internally within the device.

AUTOMATIC SECTOR ERASE

The MX29LV320AT/B is sector(s) erasable using MXIC's Auto Sector Erase algorithm. Sector erase

modes allow sectors of the array to be erased in one erase cycle. The Automatic Sector Erase algorithm automatically programs the specified sector(s) prior to electrical erase. The timing and verification of electrical erase are controlled internally within the device.

AUTOMATIC ERASE ALGORITHM

MXIC's Automatic Erase algorithm requires the user to write commands to the command register using standard microprocessor write timings. The device will automatically pre-program and verify the entire array. Then the device automatically times the erase pulse width, provides the erase verification, and counts the number of sequences. A status bit toggling between consecutive read cycles provides feedback to the user as to the status of the programming operation.

Register contents serve as inputs to an internal state-machine which controls the erase and programming circuitry. During write cycles, the command register internally latches address and data needed for the programming and erase operations. During a system write cycle, addresses are latched on the falling edge, and data are latched on the rising edge of WE .

MXIC's Flash technology combines years of EPROM experience to produce the highest levels of quality, reliability, and cost effectiveness. The MX29LV320AT/B electrically erases all bits simultaneously using Fowler-Nordheim tunneling. The bytes/words are programmed by using the EPROM programming mechanism of hot electron injection.

During a program cycle, the state-machine will control the program sequences and command register will not respond to any command set. During a Sector Erase cycle, the command register will only respond to Erase Suspend command. After Erase Suspend is completed, the device stays in read mode. After the state machine has completed its task, it will allow the command register to respond to its full command set.

PIN CONFIGURATION

48 TSOP

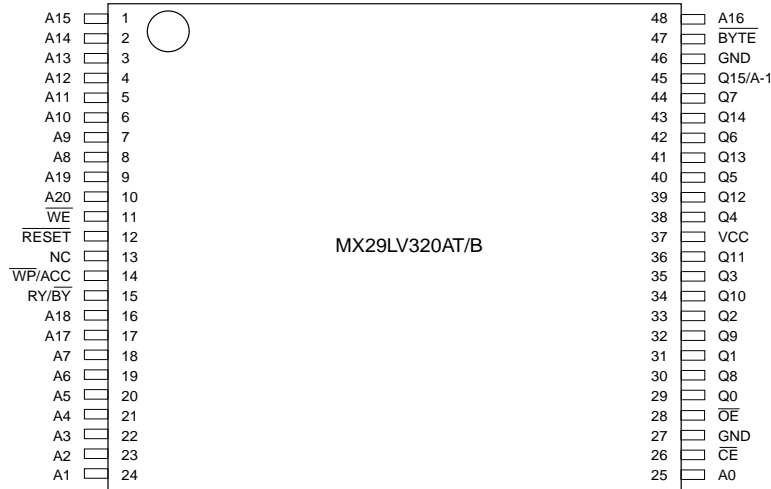

48-Ball CSP 6mm x 8mm (Ball Pitch = 0.8 mm), Top View, Balls Facing Down

	A	B	C	D	E	F	G	H
6	A13	A12	A14	A15	A16	$\overline{\text{BYTE}}$	Q15/A-1	GND
5	A9	A8	A10	A11	Q7	Q14	Q13	Q6
4	$\overline{\text{WE}}$	$\overline{\text{RESET}}$	NC	A19	Q5	Q12	Vcc	Q4
3	$\overline{\text{RY/BY}}$	$\overline{\text{WP/ACC}}$	A18	A20	Q2	Q10	Q11	Q3
2	A7	A17	A6	A5	Q0	Q8	Q9	Q1
1	A3	A4	A2	A1	A0	$\overline{\text{CE}}$	$\overline{\text{OE}}$	GND

PIN DESCRIPTION

SYMBOL	PIN NAME
A0~A20	Address Input
Q0~Q14	15 Data Inputs/Outputs
Q15/A-1	Q15(Data Input/Output, word mode) A-1(LSB Address Input, byte mode)
$\overline{\text{CE}}$	Chip Enable Input
$\overline{\text{WE}}$	Write Enable Input
$\overline{\text{OE}}$	Output Enable Input
$\overline{\text{BYTE}}$	Word/Byte Selection Input
$\overline{\text{RESET}}$	Hardware Reset Pin, Active Low
$\overline{\text{RY/BY}}$	Read/Busy Output
VCC	3.0 volt-only single power supply
$\overline{\text{WP/ACC}}$	Hardware Write Protect/Acceleration Pin
GND	Device Ground
NC	Pin Not Connected Internally

LOGIC SYMBOL

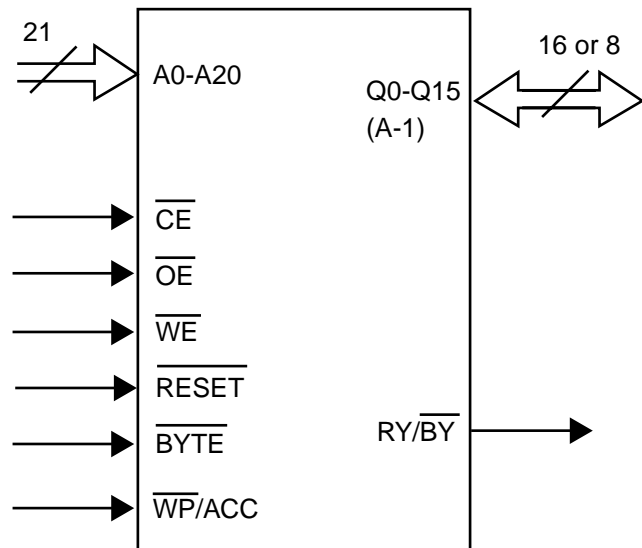

BLOCK DIAGRAM

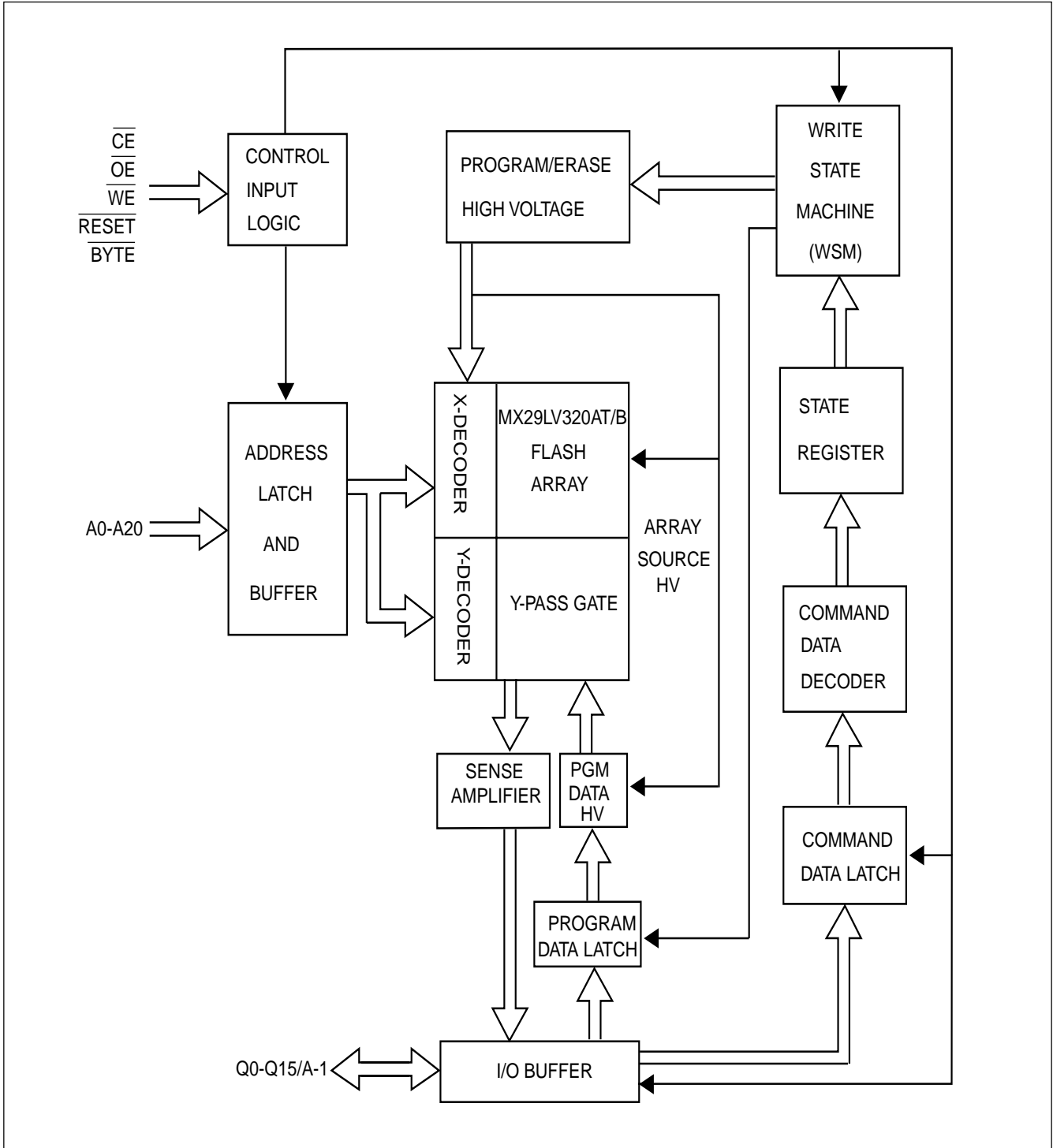

**Table 1.a: MX29LV320AT SECTOR GROUP ARCHITECTURE**

Sector Group	Sector	Sector Address A20-A12	Sector Size (Kbytes/Kwords)	(x8) Address Range	(x16) Address Range
1	SA0	000000xxx	64/32	000000h-00FFFFh	000000h-07FFFFh
1	SA1	000001xxx	64/32	010000h-01FFFFh	008000h-0FFFFh
1	SA2	000010xxx	64/32	020000h-02FFFFh	010000h-17FFFFh
1	SA3	000011xxx	64/32	030000h-03FFFFh	018000h-01FFFFh
2	SA4	000100xxx	64/32	040000h-04FFFFh	020000h-027FFFh
2	SA5	000101xxx	64/32	050000h-05FFFFh	028000h-02FFFFh
2	SA6	000110xxx	64/32	060000h-06FFFFh	030000h-037FFFh
2	SA7	000111xxx	64/32	070000h-07FFFFh	038000h-03FFFFh
3	SA8	001000xxx	64/32	080000h-08FFFFh	040000h-047FFFh
3	SA9	001001xxx	64/32	090000h-09FFFFh	048000h-04FFFFh
3	SA10	001010xxx	64/32	0A0000h-0AFFFFh	050000h-057FFFh
3	SA11	001011xxx	64/32	0B0000h-0BFFFFh	058000h-05FFFFh
4	SA12	001100xxx	64/32	0C0000h-0CFFFFh	060000h-067FFFh
4	SA13	001101xxx	64/32	0D0000h-0DFFFFh	068000h-06FFFFh
4	SA14	001110xxx	64/32	0E0000h-0EFFFFh	070000h-077FFFh
4	SA15	001111xxx	64/32	0F0000h-0FFFFFFh	078000h-07FFFFh
5	SA16	010000xxx	64/32	100000h-10FFFFh	080000h-087FFFh
5	SA17	010001xxx	64/32	110000h-11FFFFh	088000h-08FFFFh
5	SA18	010010xxx	64/32	120000h-12FFFFh	090000h-097FFFh
5	SA19	010011xxx	64/32	130000h-13FFFFh	098000h-09FFFFh
6	SA20	010100xxx	64/32	140000h-14FFFFh	0A0000h-0A7FFFh
6	SA21	010101xxx	64/32	150000h-15FFFFh	0A8000h-0AFFFFh
6	SA22	010110xxx	64/32	160000h-16FFFFh	0B0000h-0B7FFFh
6	SA23	010111xxx	64/32	170000h-17FFFFh	0B8000h-0BFFFFh
7	SA24	011000xxx	64/32	180000h-18FFFFh	0C0000h-0C7FFFh
7	SA25	011001xxx	64/32	190000h-19FFFFh	0C8000h-0CFFFFh
7	SA26	011010xxx	64/32	1A0000h-1AFFFFh	0D0000h-0D7FFFh
7	SA27	011011xxx	64/32	1B0000h-1BFFFFh	0D8000h-0DFFFFh
8	SA28	011100xxx	64/32	1C0000h-1CFFFFh	0E0000h-0E7FFFh
8	SA29	011101xxx	64/32	1D0000h-1DFFFFh	0E8000h-0EFFFFh
8	SA30	011110xxx	64/32	1E0000h-1EFFFFh	0F0000h-0F7FFFh
8	SA31	011111xxx	64/32	1F0000h-1FFFFFFh	0F8000h-0FFFFFFh
9	SA32	100000xxx	64/32	200000h-20FFFFh	100000h-107FFFh
9	SA33	100001xxx	64/32	210000h-21FFFFh	108000h-10FFFFh
9	SA34	100010xxx	64/32	220000h-22FFFFh	110000h-117FFFh
9	SA35	100011xxx	64/32	230000h-23FFFFh	118000h-11FFFFh
10	SA36	100100xxx	64/32	240000h-24FFFFh	120000h-127FFFh
10	SA37	100101xxx	64/32	250000h-25FFFFh	128000h-12FFFFh
10	SA38	100110xxx	64/32	260000h-26FFFFh	130000h-137FFFh
10	SA39	100111xxx	64/32	270000h-27FFFFh	138000h-13FFFFh



Sector Group	Sector	Sector Address A20-A12	Sector Size (Kbytes/Kwords)	(x8) Address Range	(x16) Address Range
11	SA40	101000xxx	64/32	280000h-28FFFFh	140000h-147FFFh
11	SA41	101001xxx	64/32	290000h-29FFFFh	148000h-14FFFFh
11	SA42	101010xxx	64/32	2A0000h-2AFFFFh	150000h-157FFFh
11	SA43	101011xxx	64/32	2B0000h-2BFFFFh	158000h-15FFFFh
12	SA44	101100xxx	64/32	2C0000h-2CFFFFh	160000h-147FFFh
12	SA45	101101xxx	64/32	2D0000h-2DFFFFh	168000h-14FFFFh
12	SA46	101110xxx	64/32	2E0000h-2EFFFFh	170000h-177FFFh
12	SA47	101111xxx	64/32	2F0000h-2FFFFFh	178000h-17FFFFh
13	SA48	110000xxx	64/32	300000h-30FFFFh	180000h-187FFFh
13	SA49	110001xxx	64/32	310000h-31FFFFh	188000h-18FFFFh
13	SA50	110010xxx	64/32	320000h-32FFFFh	190000h-197FFFh
13	SA51	110011xxx	64/32	330000h-33FFFFh	198000h-19FFFFh
14	SA52	110100xxx	64/32	340000h-34FFFFh	1A0000h-1A7FFFh
14	SA53	110101xxx	64/32	350000h-35FFFFh	1A8000h-1AFFFFh
14	SA54	110110xxx	64/32	360000h-36FFFFh	1B0000h-1B7FFFh
14	SA55	110111xxx	64/32	370000h-37FFFFh	1B8000h-1BFFFFh
15	SA56	111000xxx	64/32	380000h-38FFFFh	1C0000h-1C7FFFh
15	SA57	111001xxx	64/32	390000h-39FFFFh	1C8000h-1CFFFFh
15	SA58	111010xxx	64/32	3A0000h-3AFFFFh	1D0000h-1D7FFFh
15	SA59	111011xxx	64/32	3B0000h-3BFFFFh	1D8000h-1DFFFFh
16	SA60	111100xxx	64/32	3C0000h-3CFFFFh	1E0000h-1E7FFFh
16	SA61	111101xxx	64/32	3D0000h-3DFFFFh	1E8000h-1EFFFFh
16	SA62	111110xxx	64/32	3E0000h-3EFFFFh	1F0000h-1F7FFFh
17	SA63	111111000	8/4	3F0000h-3F1FFFh	1F8000h-1F8FFFh
18	SA64	111111001	8/4	3F2000h-3F3FFFh	1F9000h-1F9FFFh
19	SA65	111111010	8/4	3F4000h-3F5FFFh	1FA000h-1FAFFFh
20	SA66	111111011	8/4	3F6000h-3F7FFFh	1FB000h-1FBFFFh
21	SA67	111111100	8/4	3F8000h-3F9FFFh	1FC000h-1FCFFFh
22	SA68	111111101	8/4	3FA000h-3FBFFFh	1FD000h-1FDFFFh
23	SA69	111111110	8/4	3FC000h-3FDFFFh	1FE000h-1FEFFFh
24	SA70	111111111	8/4	3FE000h-3FFFFFh	1FF000h-1FFFFFh

Note: The address range is A20:A-1 in byte mode ($\overline{\text{BYTE}}=\text{VIL}$) or A20:A0 in word mode ($\overline{\text{BYTE}}=\text{VIH}$)

Top Boot Security Sector Addresses

Sector Address A20~A12	Sector Size (Kbytes/Kwords)	(x8) Address Range	(x16) Address Range
111111xxx	64/32	3F0000h-3FFFFFh	1F8000h-1FFFFFh



Table 1.b: MX29LV320AB SECTOR GROUP ARCHITECTURE

Sector Group	Sector	Sector Address A20-A12	Sector Size (Kbytes/Kwords)	(x8) Address Range	(x16) Address Range
1	SA0	000000000	8/4	000000h-001FFFh	000000h-000FFFh
2	SA1	000000001	8/4	002000h-003FFFh	001000h-001FFFh
3	SA2	000000010	8/4	004000h-005FFFh	002000h-002FFFh
4	SA3	000000011	8/4	006000h-007FFFh	003000h-003FFFh
5	SA4	000000100	8/4	008000h-009FFFh	004000h-004FFFh
6	SA5	000000101	8/4	00A000h-00BFFFh	005000h-005FFFh
7	SA6	000000110	8/4	00C000h-00DFFFh	006000h-006FFFh
8	SA7	000000111	8/4	00E000h-00FFFFh	007000h-007FFFh
9	SA8	000001xxx	64/32	010000h-01FFFFh	008000h-00FFFFh
9	SA9	000010xxx	64/32	020000h-02FFFFh	010000h-017FFFh
9	SA10	000011xxx	64/32	030000h-03FFFFh	018000h-01FFFFh
10	SA11	000100xxx	64/32	040000h-04FFFFh	020000h-027FFFh
10	SA12	000101xxx	64/32	050000h-05FFFFh	028000h-02FFFFh
10	SA13	000110xxx	64/32	060000h-06FFFFh	030000h-037FFFh
10	SA14	000111xxx	64/32	070000h-07FFFFh	038000h-03FFFFh
11	SA15	001000xxx	64/32	080000h-08FFFFh	040000h-047FFFh
11	SA16	001001xxx	64/32	090000h-09FFFFh	048000h-04FFFFh
11	SA17	001010xxx	64/32	0A0000h-0AFFFFh	050000h-057FFFh
11	SA18	001011xxx	64/32	0B0000h-0BFFFFh	058000h-05FFFFh
12	SA19	001100xxx	64/32	0C0000h-0CFFFFh	060000h-067FFFh
12	SA20	001101xxx	64/32	0D0000h-0DFFFFh	068000h-06FFFFh
12	SA21	001110xxx	64/32	0E0000h-0EFFFFh	070000h-077FFFh
12	SA22	001111xxx	64/32	0F0000h-0FFFFFh	078000h-07FFFFh
13	SA23	010000xxx	64/32	100000h-10FFFFh	080000h-087FFFh
13	SA24	010001xxx	64/32	110000h-11FFFFh	088000h-08FFFFh
13	SA25	010010xxx	64/32	120000h-12FFFFh	090000h-097FFFh
13	SA26	010011xxx	64/32	130000h-13FFFFh	098000h-09FFFFh
14	SA27	010100xxx	64/32	140000h-14FFFFh	0A0000h-0A7FFFh
14	SA28	010101xxx	64/32	150000h-15FFFFh	0A8000h-0AFFFFh
14	SA29	010110xxx	64/32	160000h-16FFFFh	0B0000h-0B7FFFh
14	SA30	010111xxx	64/32	170000h-17FFFFh	0B8000h-0BFFFFh
15	SA31	011000xxx	64/32	180000h-18FFFFh	0C0000h-0C7FFFh
15	SA32	011001xxx	64/32	190000h-19FFFFh	0C8000h-0CFFFFh
15	SA33	011010xxx	64/32	1A0000h-1AFFFFh	0D0000h-0D7FFFh
15	SA34	011011xxx	64/32	1B0000h-1BFFFFh	0D8000h-0DFFFFh
16	SA35	011100xxx	64/32	1C0000h-1CFFFFh	0E0000h-0E7FFFh
16	SA36	011101xxx	64/32	1D0000h-1DFFFFh	0E8000h-0EFFFFh
16	SA37	011110xxx	64/32	1E0000h-1EFFFFh	0F0000h-0F7FFFh
16	SA38	011111xxx	64/32	1F0000h-1FFFFFh	0F8000h-0FFFFFh



Sector Group	Sector	Sector Address A20-A12	Sector Size (Kbytes/Kwords)	(x8) Address Range	(x16) Address Range
17	SA39	10000xxx	64/32	200000h-20FFFFh	100000h-107FFFh
17	SA40	100001xxx	64/32	210000h-21FFFFh	108000h-10FFFFh
17	SA41	100010xxx	64/32	220000h-22FFFFh	110000h-117FFFh
17	SA42	100011xxx	64/32	230000h-23FFFFh	118000h-11FFFFh
18	SA43	100100xxx	64/32	240000h-24FFFFh	120000h-127FFFh
18	SA44	100101xxx	64/32	250000h-25FFFFh	128000h-12FFFFh
18	SA45	100110xxx	64/32	260000h-26FFFFh	130000h-137FFFh
18	SA46	100111xxx	64/32	270000h-27FFFFh	138000h-13FFFFh
19	SA47	101000xxx	64/32	280000h-28FFFFh	140000h-147FFFh
19	SA48	101001xxx	64/32	290000h-29FFFFh	148000h-14FFFFh
19	SA49	101010xxx	64/32	2A0000h-2AFFFFh	150000h-157FFFh
19	SA50	101011xxx	64/32	2B0000h-2BFFFFh	158000h-15FFFFh
20	SA51	101100xxx	64/32	2C0000h-2CFFFFh	160000h-167FFFh
20	SA52	101101xxx	64/32	2D0000h-2DFFFFh	168000h-16FFFFh
20	SA53	101110xxx	64/32	2E0000h-2EFFFFh	170000h-177FFFh
20	SA54	101111xxx	64/32	2F0000h-2FFFFFh	178000h-17FFFFh
21	SA55	110000xxx	64/32	300000h-30FFFFh	180000h-187FFFh
21	SA56	110001xxx	64/32	310000h-31FFFFh	188000h-18FFFFh
21	SA57	110010xxx	64/32	320000h-32FFFFh	190000h-197FFFh
21	SA58	110011xxx	64/32	330000h-33FFFFh	198000h-19FFFFh
22	SA59	110100xxx	64/32	340000h-34FFFFh	1A0000h-1A7FFFh
22	SA60	110101xxx	64/32	350000h-35FFFFh	1A8000h-1AFFFFh
22	SA61	110110xxx	64/32	360000h-36FFFFh	1B0000h-1B7FFFh
22	SA62	110111xxx	64/32	370000h-37FFFFh	1B8000h-1BFFFFh
23	SA63	111000xxx	64/32	380000h-38FFFFh	1C0000h-1C7FFFh
23	SA64	111001xxx	64/32	390000h-39FFFFh	1C8000h-1CFFFFh
23	SA65	111010xxx	64/32	3A0000h-3AFFFFh	1D0000h-1D7FFFh
23	SA66	111011xxx	64/32	3B0000h-3BFFFFh	1D8000h-1DFFFFh
24	SA67	111100xxx	64/32	3C0000h-3CFFFFh	1E0000h-1E7FFFh
24	SA68	111101xxx	64/32	3D0000h-3DFFFFh	1E8000h-1EFFFFh
24	SA69	111110xxx	64/32	3E0000h-3EFFFFh	1F0000h-1F7FFFh
24	SA70	111111xxx	64/32	3F0000h-3FFFFFh	1F8000h-1FFFFFh

Note: The address range is A20:A-1 in byte mode ($\overline{\text{BYTE}}=\text{VIL}$) or A20:A0 in word mode ($\overline{\text{BYTE}}=\text{VIH}$)

Bottom Boot Security Sector Addresses

Sector Address A20~A12	Sector Size (Kbytes/Kwords)	(x8) Address Range	(x16) Address Range
111111xxx	64/32	000000h-00FFFFh	00000h-07FFFh

Table 2. BUS OPERATION--1

Operation	\overline{CE}	\overline{OE}	\overline{WE}	\overline{RESET}	$\overline{WP/ACC}$	Addresses (Note 2)	Q0~Q7	Q8 ~ Q15	
								Byte=VIH	Byte=VIL
Read	L	L	H	H	L/H	A_{IN}	D_{OUT}	D_{OUT}	Q8-A14 =High-Z Q15=A-1
Write (Note 1)	L	H	L	H	Note 3	A_{IN}	D_{IN}	D_{IN}	
Accelerate Program	L	H	L	H	V_{HH}	A_{IN}	D_{IN}	D_{IN}	
Standby	$V_{CC} \pm 0.3V$	X	X	$V_{CC} \pm 0.3V$	H	X	High-Z	High-Z	High-Z
Output Disable	L	H	H	H	L/H	X	High-Z	High-Z	High-Z
Reset	X	X	X	L	L/H	X	High-Z	High-Z	High-Z
Sector Group Protect (Note 2)	L	H	L	V_{ID}	L/H	Sector Addresses, A6=L, A1=H, A0=L	D_{IN}, D_{OUT}	X	X
Chip Unprotect (Note 2)	L	H	L	V_{ID}	Note 3	Sector Addresses, A6=H, A1=H, A0=L	D_{IN}, D_{OUT}	X	X
Temporary Sector Group Unprotect	X	X	X	V_{ID}	Note 3	A_{IN}	D_{IN}	D_{IN}	High-Z

Legend:

L=Logic LOW= V_{IL} , H=Logic High= V_{IH} , $V_{ID}=12.0\pm 0.5V$, $V_{HH}=11.5-12.5V$, X=Don't Care, A_{IN} =Address IN, D_{IN} =Data IN, D_{OUT} =Data OUT

Notes:

1. When the $\overline{WP/ACC}$ pin is at V_{HH} , the device enters the accelerated program mode. See "Accelerated Program Operations" for more information.
2. The sector group protect and chip unprotect functions may also be implemented via programming equipment. See the "Sector Group Protection and Chip Unprotection" section.
3. If $\overline{WP/ACC}=V_{IL}$, the two outermost boot sectors remain protected. If $\overline{WP/ACC}=V_{IH}$, the two outermost boot sector protection depends on whether they were last protected or unprotected using the method described in "Sector/ Sector Block Protection and Unprotection". If $\overline{WP/ACC}=V_{HH}$, all sectors will be unprotected.
4. DIN or Dout as required by command sequence, data polling, or sector protection algorithm.
5. Address are A20:A0 in word mode ($\overline{BYTE}=V_{IH}$), A20:A-1 in byte mode ($\overline{BYTE}=V_{IL}$).

BUS OPERATION--2

Operation	\overline{CE}	\overline{OE}	\overline{WE}	A20 to A12	A11 to A10	A9	A8 to A7	A6	A5 to A2	A1	A0	Q0-Q7	Q8-Q15
Read Silicon ID Manufacturer Code	L	L	H	X	X	V _{ID}	X	L	X	L	L	C2H	X
Read Silicon ID MX29LV320AT	L	L	H	X	X	V _{ID}	X	L	X	L	H	A7H	22h(word) X (byte)
Read Silicon ID MX29LV320AB	L	L	H	X	X	V _{ID}	X	L	X	L	H	A8H	22h(word) X (byte)
Sector Protect Verification	L	L	H	SA	X	V _{ID}	X	L	X	H	L	01h(1), or 00h	X
Security Sector Indicater Bit (Q7)	L	L	H	X	X	V _{ID}	X	L	X	H	H	99h(2), or 19h	X

Notes:

- 1.Code=00h means unprotected, or code=01h protected.
- 2.Code=99 means factory locked, or code=19h not factory locked.

REQUIREMENTS FOR READING ARRAY DATA

To read array data from the outputs, the system must drive the \overline{CE} and \overline{OE} pins to VIL. \overline{CE} is the power control and selects the device. \overline{OE} is the output control and gates array data to the output pins. \overline{WE} should remain at VIH.

The internal state machine is set for reading array data upon device power-up, or after a hardware reset. This ensures that no spurious alteration of the memory content occurs during the power transition. No command is necessary in this mode to obtain array data. Standard microprocessor read cycles that assert valid address on the device address inputs produce valid data on the device data outputs. The device remains enabled for read access until the command register contents are altered.

WRITE COMMANDS/COMMAND SEQUENCES

To program data to the device or erase sectors of memory, the system must drive \overline{WE} and \overline{CE} to VIL, and \overline{OE} to VIH.

An erase operation can erase one sector, multiple sectors, or the entire device. Table 1 indicates the address space that each sector occupies. A "sector address" consists of the address bits required to uniquely select a sector. Writing specific address and data commands or sequences into the command register initiates device operations. Table 3 defines the valid register command sequences. Writing incorrect address and data values or writing them in the improper sequence resets the device to reading array data. Section has details on erasing a sector or the entire chip, or suspending/resuming the erase operation.

After the system writes the Automatic Select command sequence, the device enters the Automatic Select mode. The system can then read Automatic Select codes from the internal register (which is separate from the memory array) on Q7-Q0. Standard read cycle timings apply in this mode. Refer to the Automatic Select Mode and Automatic Select Command Sequence section for more information.

ICC2 in the DC Characteristics table represents the active current specification for the write mode. The "AC Characteristics" section contains timing specification table and timing diagrams for write operations.

ACCELERATED PROGRAM OPERATION

The device offers accelerated program operations through the $\overline{WP/ACC}$ function. If the system asserts V_{HH} on ACC pin, the device will provide the fast programming time to user. This function is primarily intended to allow faster manufacturing throughput during production. Removing V_{HH} from the $\overline{WP/ACC}$ pin returns the device to normal operation. Note that the $\overline{WP/ACC}$ pin must not be at V_{HH} for operations other than accelerated programming, or device damage may result.

STANDBY MODE

MX29LV320AT/B can be set into Standby mode with two different approaches. One is using both \overline{CE} and \overline{RESET} pins and the other one is using \overline{RESET} pin only.

When using both pins of \overline{CE} and \overline{RESET} , a CMOS Standby mode is achieved with both pins held at $V_{CC} \pm 0.3V$. Under this condition, the current consumed is less than 0.2uA (typ.). If both of the \overline{CE} and \overline{RESET} are held at VIH, but not within the range of $V_{CC} \pm 0.3V$, the device will still be in the standby mode, but the standby current will be larger. During Auto Algorithm operation, V_{CC} active current (ICC2) is required even $\overline{CE} = "H"$ until the operation is completed. The device can be read with standard access time (t_{CE}) from either of these standby modes.

When using only \overline{RESET} , a CMOS standby mode is achieved with \overline{RESET} input held at $V_{SS} \pm 0.3V$. Under this condition the current is consumed less than 1uA (typ.). Once the \overline{RESET} pin is taken high, the device is back to active without recovery delay.

In the standby mode the outputs are in the high impedance state, independent of the \overline{OE} input.

MX29LV320AT/B is capable to provide the Automatic Standby Mode to restrain power consumption during read-out of data. This mode can be used effectively with an application requested low power consumption such as handy terminals.

To active this mode, MX29LV320AT/B automatically switch themselves to low power mode when MX29LV320AT/B addresses remain stable during access time of $t_{ACC}+30ns$. It is not necessary to control \overline{CE} , \overline{WE} , and \overline{OE} on the mode. Under the mode, the current consumed is typically 0.2uA (CMOS level).

OUTPUT DISABLE

With the \overline{OE} input at a logic high level (VIH), output from the devices are disabled. This will cause the output pins to be in a high impedance state.

RESET OPERATION

The \overline{RESET} pin provides a hardware method of resetting the device to reading array data. When the \overline{RESET} pin is driven low for at least a period of t_{RP} , the device immediately terminates any operation in progress, tristates all output pins, and ignores all read/write commands for the duration of the \overline{RESET} pulse. The device also resets the internal state machine to reading array data. The operation that was interrupted should be reinitiated once the device is ready to accept another command sequence, to ensure data integrity

Current is reduced for the duration of the \overline{RESET} pulse. When \overline{RESET} is held at $V_{SS} \pm 0.3V$, the device draws CMOS standby current (I_{CC4}). If \overline{RESET} is held at VIL but not within $V_{SS} \pm 0.3V$, the standby current will be greater.

The \overline{RESET} pin may be tied to system reset circuitry. A system reset would that also reset the Flash memory, enabling the system to read the boot-up firm-ware from the Flash memory.

If \overline{RESET} is asserted during a program or erase operation, the RY/BY pin remains a "0" (busy) until the internal reset operation is complete, which requires a time of t_{READY} (during Embedded Algorithms). The system can thus monitor RY/BY to determine whether the reset operation is complete. If \overline{RESET} is asserted when a program or erase operation is not executing (RY/BY pin is "1"), the reset operation is completed within a time of t_{READY} (not during Embedded Algorithms). The system can read data t_{RH} after the \overline{RESET} pin returns to VIH.

Refer to the AC Characteristics tables for \overline{RESET} parameters and to Figure 14 for the timing diagram.

SECTOR GROUP PROTECT OPERATION

The MX29LV320AT/B features hardware sector group protection. This feature will disable both program and erase operations for these sector group protected. Sector protection can be implemented via two methods.

The primary method requires VID on the \overline{RESET} only. This method can be implemented either in-system or via programming equipment. This method uses standard microprocessor bus cycle timing. Refer to Figure 13 for timing diagram and Figure 14 illustrates the algorithm for the sector group protection operation.

The alternate method intended only for programming equipment, must force VID on address pin A9 and control pin \overline{OE} , (suggest VID = 12V) $A6 = V_{IL}$ and $\overline{CE} = V_{IL}$ (see Table 2). Programming of the protection circuitry begins on the falling edge of the \overline{WE} pulse and is terminated on the rising edge. Contact MXIC for details.

To verify programming of the protection circuitry, the programming equipment must force V_{ID} on address pin A9 (with \overline{CE} and \overline{OE} at VIL and \overline{WE} at VIH). When $A1=1$, it will produce a logical "1" code at device output Q0 for a protected sector. Otherwise the device will produce 00H for the unprotected sector. In this mode, the addresses, except for A1, are don't care. Address locations with $A1=V_{IL}$ are reserved to read manufacturer and device codes. (Read Silicon ID)

It is also possible to determine if the group is protected in the system by writing a Read Silicon ID command. Performing a read operation with $A1=VIH$, it will produce a logical "1" at Q0 for the protected sector.

CHIP UNPROTECT OPERATION

The MX29LV320AT/B also features the chip unprotect mode, so that all sectors are unprotected after chip unprotect is completed to incorporate any changes in the code. It is recommended to protect all sectors before activating chip unprotect mode.

The primary method requires VID on the \overline{RESET} only. This method can be implemented either in-system or via programming equipment. This method uses standard microprocessor bus cycle timing. Refer to Figure 13 for timing diagram and Figure 14 illustrates the algorithm for the sector group protection operation.

The alternate method intended only for programming equipment, must force VID on address pin A9 and control pin \overline{OE} , (suggest VID = 12V) $A6 = V_{IL}$ and $\overline{CE} = V_{IL}$ (see Table 2). Programming of the protection circuitry begins on the falling edge of the \overline{WE} pulse and is terminated on the rising edge. Contact MXIC for details.

It is also possible to determine if the chip is unprotected in the system by writing the Read Silicon ID command. Performing a read operation with A1=VIH, it will produce 00H at data outputs(Q0-Q7) for an unprotected sector. It is noted that all sectors are unprotected after the chip unprotect algorithm is completed.

TEMPORARY SECTOR GROUP UNPROTECT OPERATION

This feature allows temporary unprotection of previously protected sector to change data in-system. The Temporary Sector Unprotect mode is activated by setting the RESET pin to V_{ID} (11.5V-12.5V). During this mode, formerly protected sectors can be programmed or erased as un-protected sector. Once V_{ID} is remove from the RESET pin, all the previously protected sectors are protected again.

WRITE PROTECT (\overline{WP})

The write protect function provides a hardware method to protect boot sectors without using V_{ID} .

If the system asserts VIL on the \overline{WP}/ACC pin, the device disables program and erase functions in the two "outermost" 8 Kbyte boot sectors independently of whether those sectors were protected or unprotected using the method described in "Sector/Sector Group Protection and Chip Unprotection". The two outermost 8 Kbyte boot sectors are the two sectors containing the lowest addresses in a bottom-boot-configured device, or the two sectors containing the highest addresses in a top-boot-configured device.

If the system asserts VIH on the \overline{WP}/ACC pin, the device reverts to whether the two outermost 8K Byte boot sectors were last set to be protected or unprotected. That is, sector protection or unprotection for these two sectors depends on whether they were last protected or unprotected using the method described in "Sector/Sector Group Protection and Chip Unprotection".

Note that the \overline{WP}/ACC pin must not be left floating or unconnected; inconsistent behavior of the device may result.

AUTOMATIC SELECT OPERATION

Flash memories are intended for use in applications where the local CPU alters memory contents. As such, manufacturer and device codes must be accessible while the device resides in the target system. PROM programmers typically access signature codes by raising A9 to a high voltage. However, multiplexing high voltage onto address lines is not generally desired system design practice.

MX29LV320AT/B provides hardware method to access the Automatic Select operation. This method requires V_{ID} on A9 pin, VIL on \overline{CE} , \overline{OE} , A6, and A1 pins. When applying VIL on A0 pin, the device will output MXIC's manufacture code of C2H. When applying VIH on A0 pin, the device will output MX29LV320AT/B device code of 22A7h and 22A8h.

VERIFY SECTOR GROUP PROTECT STATUS OPERATION

MX29LV320AT/B provides hardware method for sector group protect status verify. This method requires V_{ID} on A9 pin, VIH on \overline{WE} and A1 pins, VIL on \overline{CE} , \overline{OE} , A6, and A0 pins, and sector address on A12 to A20 pins. When the identified sector is protected, the device will output 01H. When the identified sector is not protect, the device will output 00H.

SECURITY SECTOR FLASH MEMORY REGION

The Security Sector (Security Sector) feature provides a Flash memory region that enables permanent part identification through an Electronic Serial Number (ESN). The Security Sector is 64 Kbytes (32 Kwords) in length, and uses a Security Sector Indicator Bit (Q7) to indicate whether or not the Security Sector is locked when shipped from the factory. This bit is per-manently set at the factory and cannot be changed, which prevents cloning of a factory locked part. This ensures the security of the ESN once the product is shipped to the field.

MXIC offers the device with the Security Sector either factory locked or customer lockable. The factory-locked version is always protected when shipped from the factory, and has the Security on Silicon Sector (Security Sector) Indicator Bit permanently set to a "1". The customer-lockable version is shipped with the unprotected, allowing customers to utilize the that sector in any man-

ner they choose. The customer-lockable version has the Security on Silicon Sector (Security Sector) Indicator Bit permanently set to a "0". Thus, the Security Sector Indicator Bit prevents customer-lockable devices from being used to replace devices that are factory locked.

The system accesses the Security Sector through a command sequence (see "Enter Security Sector/Exit Security Sector Command Sequence"). After the system has written the Enter Security Sector command sequence, it may read the Security Sector by using the addresses normally occupied by the boot sectors. This mode of operation continues until the system issues the Exit Security Sector command sequence, or until power is removed from the device. On power-up, or following a hardware reset, the device reverts to sending commands to the boot sectors.

Factory Locked: Security Sector Programmed and Protected at the Factory

In a factory locked device, the Security Sector is protected when the device is shipped from the factory. The Security Sector cannot be modified in any way. The device is available preprogrammed with one of the following:

- A random, secure ESN only.
- Customer code through the Express Flash service.
- Both a random, secure ESN and customer code through the Express Flash service.

In devices that have an ESN, a Bottom Boot device will have the 16-byte (8-word) ESN in the lowest addressable memory area starting at 00000h and ending at 0000Fh (00007h). In the Top Boot device the starting address of the ESN will be at the bottom of the lowest 8 Kbyte (4 Kword) boot sector starting at 3F0000h (1F8000h) and ending at 3F000Fh (1F8007h).

Customer Lockable: Security Sector NOT Programmed or Protected at the Factory

If the security feature is not required, the Security Sector can be treated as an additional Flash memory space, expanding the size of the available Flash array by 64 Kbytes (32 Kwords). The Security Sector can be read, programmed, and erased as often as required. The Security Sector area can be protected using one of the following procedures:

Write the three-cycle Enter Security Region command sequence, and then follow the in-system sector group protect algorithm as shown in Figure 14, except that $\overline{\text{RESET}}$ may be at either V_{IH} or V_{ID} . This allows in-system protection of the without raising any device pin to a high voltage. Note that this method is only applicable to the Security Sector.

Write the three-cycle Enter Security Region command sequence, and then use the alternate method of sector protection described in the "Sector/Sector Block Protection and Unprotection" section.

Once the Security Sector is locked and verified, the system must write the Exit Security Sector Region command sequence to return to reading and writing the remainder of the array.

The Security Sector protection must be used with caution since, once protected, there is no procedure available for unprotecting the Security Sector area and none of the bits in the Security Sector memory space can be modified in any way.

DATA PROTECTION

The MX29LV320AT/B is designed to offer protection against accidental erasure or programming caused by spurious system level signals that may exist during power transition. During power up the device automatically resets the state machine in the Read mode. In addition, with its control register architecture, alteration of the memory contents only occurs after successful completion of specific command sequences. The device also incorporates several features to prevent inadvertent write cycles resulting from VCC power-up and power-down transition or system noise.

LOW VCC WRITE INHIBIT

When VCC is less than VLKO the device does not accept any write cycles. This protects data during VCC power-up and power-down. The command register and all internal program/erase circuits are disabled, and the device resets. Subsequent writes are ignored until VCC is greater than VLKO. The system must provide the proper signals to the control pins to prevent unintentional write when VCC is greater than VLKO.

WRITE PULSE "GLITCH" PROTECTION

Noise pulses of less than 5ns (typical) on \overline{OE} , \overline{CE} or \overline{WE} will not initiate a write cycle.

LOGICAL INHIBIT

Writing is inhibited by holding any one of $\overline{OE} = V_{IL}$, $\overline{CE} = V_{IH}$ or $\overline{WE} = V_{IH}$. To initiate a write cycle \overline{CE} and \overline{WE} must be a logical zero while \overline{OE} is a logical one.

POWER-UP SEQUENCE

The MX29LV320AT/B powers up in the Read only mode. In addition, the memory contents may only be altered after successful completion of the predefined command sequences.

POWER-UP WRITE INHIBIT

If $\overline{WE} = \overline{CE} = V_{IL}$ and $\overline{OE} = V_{IH}$ during power up, the device does not accept commands on the rising edge of \overline{WE} . The internal state machine is automatically reset to the read mode on power-up.

POWER SUPPLY DECOUPLING

In order to reduce power switching effect, each device should have a 0.1 μ F ceramic capacitor connected between its VCC and GND.

SOFTWARE COMMAND DEFINITIONS

Device operations are selected by writing specific address and data sequences into the command register. Writing incorrect address and data values or writing them in the improper sequence will reset the device to the read mode. Table 3 defines the valid register command sequences. Note that the Erase Suspend (B0H) and Erase Resume (30H) commands are valid only while the Sector Erase operation is in progress. Either of the two reset command sequences will reset the device (when applicable).

All addresses are latched on the falling edge of \overline{WE} or \overline{CE} , whichever happens later. All data are latched on rising edge of \overline{WE} or \overline{CE} , whichever happens first.

TABLE 3. MX29LV320AT/B COMMAND DEFINITIONS

Command	Bus Cycles	First Bus Cycle		Second Bus Cycle		Third Bus Cycle		Fourth Bus Cycle		Fifth Bus Cycle		Sixth Bus Cycle		
		Addr	Data	Addr	Data	Addr	Data	Addr	Data	Addr	Data	Addr	Data	
Read(Note 5)	1	RA	RD											
Reset(Note 4)	1	XXX	F0											
Automatic Select(Note 5)														
Manufacturer ID	Word	4	555	AA	2AA	55	555	90	X00	C2H				
	Byte	4	AAA	AA	555	55	AAA	90	X00	C2H				
Device ID	Word	4	555	AA	2AA	55	555	90	X01	ID				
	Byte	4	AAA	AA	555	55	AAA	90	X02					
Security Sector Factory Protect Verify (Note 6)	Word	4	555	AA	2AA	55	555	90	X03	99/19				
	Byte	4	AAA	AA	555	55	AAA	90	X06					
Sector Protect Verify (Note 7)	Word	4	555	AA	2AA	55	555	90	(SA)X02	00/01				
	Byte	4	AAA	AA	555	55	AAA	90	(SA)X04					
Enter Security Sector Region	Word	3	555	AA	2AA	55	555	88						
	Byte	3	AAA	AA	555	55	AAA	88						
Exit Security Sector	Word	4	555	AA	2AA	55	555	90	XXX	00				
	Byte	4	AAA	AA	555	55	AAA	90	XXX	00				
Program	Word	4	555	AA	2AA	55	555	A0	PA	PD				
	Byte	4	AAA	AA	555	55	AAA	A0	PA	PD				
Chip Erase	Word	6	555	AA	2AA	55	555	80	555	AA	2AA	55	555	10
	Byte	6	AAA	AA	555	55	AAA	80	AAA	AA	555	55	AAA	10
Sector Erase	Word	6	555	AA	2AA	55	555	80	555	AA	2AA	55	SA	30
	Byte	6	AAA	AA	555	55	AAA	80	AAA	AA	555	55	SA	30
CFI Query (Note 8)	Word	1	55	98										
	Byte	1	AA	98										
Erase Suspend(Note 9)	1	SA	B0											
Erase Resume(Note 10)	1	SA	30											

Legend:

X=Don't care

RA=Address of the memory location to be read.

RD=Data read from location RA during read operation.

PA=Address of the memory location to be programmed.

 Addresses are latched on the falling edge of the \overline{WE} or \overline{CE} pulse.

 PD=Data to be programmed at location PA. Data is latched on the rising edge of \overline{WE} or \overline{CE} pulse.

SA=Address of the sector to be erased or verified. Address bits A20-A12 uniquely select any sector.

ID=22A7h(Top), 22A8h(Bottom)

Notes:

- See Table 1 for descriptions of bus operations.
- All values are in hexadecimal.
- Except when reading array or Automatic Select data, all bus cycles are write operation.
- The Reset command is required to return to the read mode when the device is in the Automatic Select mode or if Q5 goes high.
- The fourth cycle of the Automatic Select command sequence is a read cycle.
- The data is 99h for factory locked and 19h for not factory locked.
- The data is 00h for an unprotected sector/sector block and 01h for a protected sector/sector block. In the third cycle of the command sequence, address bit A20=0 to verify sectors 0~31, A20=1 to verify sectors 32~70 for Top Boot device.
- Command is valid when device is ready to read array data or when device is in Automatic Select mode.
- The system may read and program functions in non-erasing sectors, or enter the Automatic Select mode, when in the erase Suspend mode. The Erase Suspend command is valid only during a sector erase operation.
- The Erase Resume command is valid only during the Erase Suspend mode.

READING ARRAY DATA

The device is automatically set to reading array data after device power-up. No commands are required to retrieve data. The device is also ready to read array data after completing an Automatic Program or Automatic Erase algorithm.

After the device accepts an Erase Suspend command, the device enters the Erase Suspend mode. The system can read array data using the standard read timings, except that if it reads at an address within erase-suspended sectors, the device outputs status data. After completing a programming operation in the Erase Suspend mode, the system may once again read array data with the same exception. See "Erase Suspend/Erased Resume Commands" for more information on this mode. The system must issue the reset command to re-enable the device for reading array data if Q5 goes high during an active program or erase operation, or while in the Automatic Select mode. See the "Reset Command" section, next.

RESET COMMAND

Writing the reset command to the device resets the device to reading array data. Address bits are don't care for this command.

The reset command may be written between the sequence cycles in an erase command sequence before erasing begins. This resets the device to reading array data. Once erasure begins, however, the device ignores reset commands until the operation is complete.

The reset command may be written between the sequence cycles in a program command sequence before programming begins. This resets the device to reading array data (also applies to programming in Erase Suspend mode). Once programming begins, however, the device ignores reset commands until the operation is complete.

The reset command may be written between the sequence cycles in an Automatic Select command sequence. Once in the Automatic Select mode, the reset command must be written to return to reading array data (also applies to Automatic Select during Erase Suspend).

If Q5 goes high during a program or erase operation, writing the reset command returns the device to reading array data (also applies during Erase Suspend).

AUTOMATIC SELECT COMMAND SEQUENCE

The Automatic Select command sequence allows the host system to access the manufacturer and device codes, and determine whether or not a sector is protected. Table 2 shows the address and data requirements. This method is an alternative to that shown in Table 3, which is intended for EPROM programmers and requires V_{DD} on address bit A9.

The Automatic Select command sequence is initiated by writing two unlock cycles, followed by the Automatic Select command. The device then enters the Automatic Select mode, and the system may read at any address any number of times, without initiating another command sequence. A read cycle at address XX00h retrieves the manufacturer code. A read cycle at address XX01h in word mode (or xx02h in byte mode) returns the device code. A read cycle containing a sector address (SA) and the address 02h on A7-A0 in word mode (or the address 04h on A6-A-1 in byte mode) returns 01h if that sector is protected, or 00h if it is unprotected. Refer to Table 1 for valid sector addresses.

The system must write the reset command to exit the Automatic Select mode and return to reading array data.

ENTER SECURITY SECTOR & EXIT SECURITY SECTOR COMMAND SEQUENCE

The Security Sector provides a secured area which contains a random, sixteen-byte electronic serial number (ESN).

The system can access the Security Sector area by issuing the three-cycle "Enter Security Sector command sequence. The device continues to access the security section area until the system issues the four-cycle Exit Security Sector command sequence. The Exit Security Sector command sequence returns the device to normal operation.

BYTE/WORD PROGRAM COMMAND SEQUENCE

The device programs one byte/word of data for each program operation. The command sequence requires four bus cycles, and is initiated by writing two unlock write cycles, followed by the program set-up command. The program address and data are written next, which in turn initiate the Embedded Program algorithm. The system is not required to provide further controls or timings. The device automatically generates the program pulses and

verifies the programmed cell margin. Table 3 shows the address and data requirements for the byte/word program command sequence.

When the Embedded Program algorithm is complete, the device then returns to reading array data and addresses are no longer latched. The system can determine the status of the program operation by using Q7, Q6, or RY/BY. See "Write Operation Status" for information on these status bits.

Any commands written to the device during the Embedded Program Algorithm are ignored. Note that a hardware reset immediately terminates the programming operation. The Byte/Word Program command sequence should be reinitiated once the device has reset to reading array data, to ensure data integrity.

Programming is allowed in any sequence and across sector boundaries. A bit cannot be programmed from a "0" back to a "1". Attempting to do so may cause the device to set Q5 to "1", or cause the Data Polling algorithm to indicate the operation was successful.

However, a succeeding read will show that the data is still "0". Only erase operations can convert a "0" to a "1".

SETUP AUTOMATIC CHIP/SECTOR ERASE

Chip erase is a six-bus cycle operation. There are two "unlock" write cycles. These are followed by writing the "set-up" command 80H. Two more "unlock" write cycles are then followed by the chip erase command 10H, or the sector erase command 30H.

The MX29LV320AT/B contains a Silicon-ID-Read operation to supplement traditional PROM programming methodology. The operation is initiated by writing the read silicon ID command sequence into the command register. Following the command write, a read cycle with A1=VIL, A0=VIL retrieves the manufacturer code of C2H. A read cycle with A1=VIL, A0=VIH returns the device code of A7H/A8H for MX29LV320AT/B.

TABLE 4. SILICON ID CODE

Pins	A0	A1	Q7	Q6	Q5	Q4	Q3	Q2	Q1	Q0	Code(Hex)
Manufacture code	VIL	VIL	1	1	0	0	0	0	1	0	C2H
Device code for MX29LV320AT	VIH	VIL	1	0	1	0	0	1	1	1	22A7H
Device code for MX29LV320AB	VIH	VIL	1	0	1	0	1	0	0	0	22A8H

AUTOMATIC CHIP/SECTOR ERASE COMMAND

The device does not require the system to preprogram prior to erase. The Automatic Erase algorithm automatically preprograms and verifies the entire memory for an all zero data pattern prior to electrical erase. The system is not required to provide any controls or timings during these operations. Table 3 shows the address and data requirements for the chip erase command sequence.

Any commands written to the chip during the Automatic Erase algorithm are ignored. Note that a hardware reset during the chip erase operation immediately terminates the operation. The Chip Erase command sequence should

be reinitiated once the device has returned to reading array data, to ensure data integrity.

The system can determine the status of the erase operation by using Q7, Q6, Q2, or RY/BY. See "Write Operation Status" for information on these status bits. When the Automatic Erase algorithm is complete, the device returns to reading array data and addresses are no longer latched.

Figure 5 illustrates the algorithm for the erase operation. See the Erase/Program Operations tables in "AC Characteristics" for parameters, and to Figure 4 for timing diagrams.

SECTOR ERASE COMMANDS

The device does not require the system to entirely pre-program prior to executing the Automatic Set-up Sector Erase command and Automatic Sector Erase command. Upon executing the Automatic Sector Erase command, the device will automatically program and verify the sector(s) memory for an all-zero data pattern. The system is not required to provide any control or timing during these operations.

When the sector(s) is automatically verified to contain an all-zero pattern, a self-timed sector erase and verify begin. The erase and verify operations are complete when the data on Q7 is "1" and the data on Q6 stops toggling for two consecutive read cycles, at which time the device returns to the Read mode. The system is not required to provide any control or timing during these operations.

When using the Automatic Sector Erase algorithm, note that the erase automatically terminates when adequate erase margin has been achieved for the memory array (no erase verification command is required). Sector erase is a six-bus cycle operation. There are two "unlock" write cycles. These are followed by writing the set-up command 80H. Two more "unlock" write cycles are then followed by the sector erase command 30H. The sector address is latched on the falling edge of \overline{WE} or \overline{CE} , whichever happens later, while the command(data) is latched on the rising edge of \overline{WE} or \overline{CE} , whichever happens first. Sector addresses selected are loaded into internal register on the sixth falling edge of \overline{WE} or \overline{CE} , whichever happens later. Each successive sector load cycle started by the falling edge of \overline{WE} or \overline{CE} , whichever happens later must begin within 50us from the rising edge of the preceding \overline{WE} or \overline{CE} , whichever happens first. Otherwise, the loading period ends and internal auto sector erase cycle starts. (Monitor Q3 to determine if the sector erase timer window is still open, see section Q3, Sector Erase Timer.) Any command other than Sector Erase(30H) or Erase Suspend(B0H) during the time-out period resets the device to read mode.

ERASE SUSPEND

This command only has meaning while the state machine is executing Automatic Sector Erase operation, and therefore will only be responded during Automatic

Sector Erase operation. When the Erase Suspend command is issued during the sector erase operation, the device requires a maximum 20us to suspend the sector erase operation. However, When the Erase Suspend command is written during the sector erase time-out, the device immediately terminates the time-out period and suspends the erase operation. After this command has been executed, the command register will initiate erase suspend mode. The state machine will return to read mode automatically after suspend is ready. At this time, state machine only allows the command register to respond to the Erase Resume, program data to, or read data from any sector not selected for erasure. The system can use Q7, or Q6 and Q2 together, to determine if a sector is actively erasing or is erase-suspended.

The system can determine the status of the program operation using the Q7 or Q6 status bits, just as in the standard program operation. After an erase-suspend program operation is complete, the system can once again read array data within non-suspended blocks.

ERASE RESUME

This command will cause the command register to clear the suspend state and return back to Sector Erase mode but only if an Erase Suspend command was previously issued. Erase Resume will not have any effect in all other conditions. Another Erase Suspend command can be written after the chip has resumed erasing.

WRITE OPERATION STATUS

The device provides several bits to determine the status of a write operation: Q2, Q3, Q5, Q6, Q7, and RY/BY. Table 5 and the following subsections describe the functions of these bits. Q7, RY/BY, and Q6 each offer a

method for determining whether a program or erase operation is complete or in progress. These three bits are discussed first.

Table 5. Write Operation Status

Status		Q7 Note1	Q6	Q5 Note2	Q3	Q2	RY/BY	
In Progress	Byte/Word Program in Auto Program Algorithm	$\overline{Q7}$	Toggle	0	N/A	No Toggle	0	
	Auto Erase Algorithm	0	Toggle	0	1	Toggle	0	
	Erase Suspended Mode	Erase Suspend Read (Erase Suspended Sector)	1	No Toggle	0	N/A	Toggle	1
		Erase Suspend Read (Non-Erase Suspended Sector)	Data	Data	Data	Data	Data	1
	Erase Suspend Program	$\overline{Q7}$	Toggle	0	N/A	N/A	0	
Exceeded Time Limits	Byte/Word Program in Auto Program Algorithm	$\overline{Q7}$	Toggle	1	N/A	No Toggle	0	
	Auto Erase Algorithm	0	Toggle	1	1	Toggle	0	
	Erase Suspend Program	$\overline{Q7}$	Toggle	1	N/A	N/A	0	

Notes:

1. Performing successive read operations from the erase-suspended sector will cause Q2 to toggle.
2. Performing successive read operations from any address will cause Q6 to toggle.
3. Reading the byte/word address being programmed while in the erase-suspend program mode will indicate logic "1" at the Q2 bit.
However, successive reads from the erase-suspended sector will cause Q2 to toggle.

Q7: Data Polling

The Data Polling bit, Q7, indicates to the host system whether an Automatic Algorithm is in progress or completed, or whether the device is in Erase Suspend. Data Polling is valid after the rising edge of the final \overline{WE} pulse in the program or erase command sequence.

During the Automatic Program algorithm, the device outputs on Q7 the complement of the datum programmed to Q7. This Q7 status also applies to programming during Erase Suspend. When the Automatic Program algorithm is complete, the device outputs the datum programmed to Q7. The system must provide the program address to read valid status information on Q7. If a program address falls within a protected sector, Data Polling on Q7 is active for approximately 1 us, then the device returns to reading array data.

During the Automatic Erase algorithm, Data Polling produces a "0" on Q7. When the Automatic Erase algorithm is complete, or if the device enters the Erase Suspend mode, Data Polling produces a "1" on Q7. This is analogous to the complement/true datum out-put described for the Automatic Program algorithm: the erase function changes all the bits in a sector to "1" prior to this, the device outputs the "complement," or "0." The system must provide an address within any of the sectors selected for erasure to read valid status information on Q7.

After an erase command sequence is written, if all sectors selected for erasing are protected, Data Polling on Q7 is active for approximately 100 us, then the device returns to reading array data. If not all selected sectors are protected, the Automatic Erase algorithm erases the unprotected sectors, and ignores the selected sectors that are protected.

When the system detects Q7 has changed from the complement to true data, it can read valid data at Q7-Q0 on the following read cycles. This is because Q7 may change asynchronously with Q0-Q6 while Output Enable (\overline{OE}) is asserted low.

Q6: Toggle BIT I

Toggle Bit I on Q6 indicates whether an Automatic Program or Erase algorithm is in progress or complete, or whether the device has entered the Erase Suspend mode. Toggle Bit I may be read at any address, and is valid

after the rising edge of the final \overline{WE} or \overline{CE} , whichever happens first pulse in the command sequence (prior to the program or erase operation), and during the sector time-out.

During an Automatic Program or Erase algorithm operation, successive read cycles to any address cause Q6 to toggle. The system may use either \overline{OE} or \overline{CE} to control the read cycles. When the operation is complete, Q6 stops toggling.

After an erase command sequence is written, if all sectors selected for erasing are protected, Q6 toggles for 100us and returns to reading array data. If not all selected sectors are protected, the Automatic Erase algorithm erases the unprotected sectors, and ignores the selected sectors that are protected.

The system can use Q6 and Q2 together to determine whether a sector is actively erasing or is erase suspended. When the device is actively erasing (that is, the Automatic Erase algorithm is in progress), Q6 toggling. When the device enters the Erase Suspend mode, Q6 stops toggling. However, the system must also use Q2 to determine which sectors are erasing or erase-suspended. Alternatively, the system can use Q7.

If a program address falls within a protected sector, Q6 toggles for approximately 2us after the program command sequence is written, then returns to reading array data.

Q6 also toggles during the erase-suspend-program mode, and stops toggling once the Automatic Program algorithm is complete.

Table 5 shows the outputs for Toggle Bit I on Q6.

Q2: Toggle Bit II

The "Toggle Bit II" on Q2, when used with Q6, indicates whether a particular sector is actively erasing (that is, the Automatic Erase algorithm is in process), or whether that sector is erase-suspended. Toggle Bit II is valid after the rising edge of the final \overline{WE} or \overline{CE} , whichever happens first pulse in the command sequence.

Q2 toggles when the system reads at addresses within those sectors that have been selected for erasure. (The system may use either \overline{OE} or \overline{CE} to control the read

cycles.) But Q2 cannot distinguish whether the sector is actively erasing or is erase-suspended. Q6, by comparison, indicates whether the device is actively erasing, or is in Erase Suspend, but cannot distinguish which sectors are selected for erasure. Thus, both status bits are required for sectors and mode information. Refer to Table 5 to compare outputs for Q2 and Q6.

Reading Toggle Bits Q6/ Q2

Whenever the system initially begins reading toggle bit status, it must read Q7-Q0 at least twice in a row to determine whether a toggle bit is toggling. Typically, the system would note and store the value of the toggle bit after the first read. After the second read, the system would compare the new value of the toggle bit with the first. If the toggle bit is not toggling, the device has completed the program or erase operation. The system can read array data on Q7-Q0 on the following read cycle.

However, if after the initial two read cycles, the system determines that the toggle bit is still toggling, the system also should note whether the value of Q5 is high (see the section on Q5). If it is, the system should then determine again whether the toggle bit is toggling, since the toggle bit may have stopped toggling just as Q5 went high. If the toggle bit is no longer toggling, the device has successfully completed the program or erase operation. If it is still toggling, the device did not complete the operation successfully, and the system must write the reset command to return to reading array data.

The remaining scenario is that system initially determines that the toggle bit is toggling and Q5 has not gone high. The system may continue to monitor the toggle bit and Q5 through successive read cycles, determining the status as described in the previous paragraph. Alternatively, it may choose to perform other system tasks. In this case, the system must start at the beginning of the algorithm when it returns to determine the status of the operation.

Q5:Program/Erase Timing

Q5 will indicate if the program or erase time has exceeded the specified limits(internal pulse count). Under these conditions Q5 will produce a "1". This time-out condition indicates that the program or erase cycle was not successfully completed. $\overline{\text{Data}}$ Polling and Toggle Bit are the

only operating functions of the device under this condition.

If this time-out condition occurs during sector erase operation, it specifies that a particular sector is bad and it may not be reused. However, other sectors are still functional and may be used for the program or erase operation. The device must be reset to use other sectors. Write the Reset command sequence to the device, and then execute program or erase command sequence. This allows the system to continue to use the other active sectors in the device.

If this time-out condition occurs during the chip erase operation, it specifies that the entire chip is bad or combination of sectors are bad.

If this time-out condition occurs during the byte/word programming operation, it specifies that the entire sector containing that byte/word is bad and this sector may not be reused, (other sectors are still functional and can be reused).

The time-out condition may also appear if a user tries to program a non blank location without erasing. In this case the device locks out and never completes the Automatic Algorithm operation. Hence, the system never reads a valid data on Q7 bit and Q6 never stops toggling. Once the Device has exceeded timing limits, the Q5 bit will indicate a "1". Please note that this is not a device failure condition since the device was incorrectly used.

The Q5 failure condition may appear if the system tries to program a "1" to a location that is previously programmed to "0". Only an erase operation can change a "0" back to a "1". Under this condition, the device halts the operation, and when the operation has exceeded the timing limits, Q5 produces a "1".

Q3:Sector Erase Timer

After the completion of the initial sector erase command sequence, the sector erase time-out will begin. Q3 will remain low until the time-out is complete. $\overline{\text{Data}}$ Polling and Toggle Bit are valid after the initial sector erase command sequence.

If $\overline{\text{Data}}$ Polling or the Toggle Bit indicates the device has been written with a valid erase command, Q3 may be used to determine if the sector erase timer window is

still open. If Q3 is high ("1") the internally controlled erase cycle has begun; attempts to write subsequent commands to the device will be ignored until the erase operation is completed as indicated by Data Polling or Toggle Bit. If Q3 is low ("0"), the device will accept additional sector erase commands. To insure the command has been accepted, the system software should check the status of Q3 prior to and following each subsequent sector erase command. If Q3 were high on the second status check, the command may not have been accepted.

If the time between additional erase commands from the system can be less than 50us, the system need not to monitor Q3.

RY/ $\overline{\text{BY}}$:READY/ $\overline{\text{BUSY}}$ OUTPUT

The RY/ $\overline{\text{BY}}$ is a dedicated, open-drain output pin that indicates whether an Embedded Algorithm is in progress or complete. The RY/ $\overline{\text{BY}}$ status is valid after the rising edge of the final WE pulse in the command sequence. Since RY/ $\overline{\text{BY}}$ is an open-drain output, several RY/ $\overline{\text{BY}}$ pins can be tied together in parallel with a pull-up resistor to VCC .

If the output is low (Busy), the device is actively erasing or programming. (This includes programming in the Erase Suspend mode.) If the output is high (Ready), the device is ready to read array data (including during the Erase Suspend mode), or is in the standby mode.

QUERY COMMAND AND COMMON FLASH

INTERFACE (CFI) MODE

MX29LV320AT/B is capable of operating in the CFI mode. This mode all the host system to determine the manufacturer of the device such as operating parameters and configuration. Two commands are required in CFI mode. Query command of CFI mode is placed first, then the Reset command exits CFI mode. These are described in Table 3.

The single cycle Query command is valid only when the device is in the Read mode, including Erase Suspend, Standby mode, and Automatic Select mode; however, it is ignored otherwise.

The Reset command exits from the CFI mode to the Read mode, or Erase Suspend mode, or Automatic Se-

lect mode. The command is valid only when the device is in the CFI mode.

Table 6-1. CFI mode: Identification Data Values

(All values in these tables are in hexadecimal)

Description	Address (h)	Address (h)	Data (h)
	(Word Mode)	(Byte Mode)	
Query-unique ASCII string "QRY"	10	20	0051
	11	22	0052
	12	24	0059
Primary vendor command set and control interface ID code	13	26	0002
	14	28	0000
Address for primary algorithm extended query table	15	2A	0040
	16	2C	0000
Alternate vendor command set and control interface ID code (none)	17	2E	0000
	18	30	0000
Address for secondary algorithm extended query table (none)	19	32	0000
	1A	34	0000

Table 6-2. CFI Mode: System Interface Data Values

Description	Address (h)	Address (h)	Data (h)
	(Word Mode)	(Byte Mode)	
VCC supply, minimum (2.7V)	1B	36	0027
VCC supply, maximum (3.6V)	1C	38	0036
VPP supply, minimum (none)	1D	3A	0000
VPP supply, maximum (none)	1E	3C	0000
Typical timeout for single word/byte write (2^N us)	1F	3E	0004
Typical timeout for maximum size buffer write (2^N us) (not supported)	20	40	0000
Typical timeout for individual sector erase (2^N ms)	21	42	000A
Typical timeout for full chip erase (2^N ms)	22	44	0000
Maximum timeout for single word/byte write times (2^N X Typ)	23	46	0005
Maximum timeout for maximum size buffer write times (2^N X Typ)	24	48	0000
Maximum timeout for individual sector erase times (2^N X Typ)	25	4A	0004
Maximum timeout for full chip erase times (not supported)	26	4C	0000

Table 6-3. CFI Mode: Device Geometry Data Values

Description	Address (h)	Address (h)	Data (h)
	(Word Mode)	(Byte Mode)	
Device size (2 ^N bytes)	27	4E	0016
Flash device interface code (02=asynchronous x8/x16)	28	50	0002
	29	52	0000
Maximum number of bytes in multi-byte write (not supported)	2A	54	0000
	2B	56	0000
Number of erase sector regions	2C	58	0002
Erase Sector Region 1 Information	2D	5A	0007
[2E, 2D] = # of same-size sectors in region 1-1	2E	5C	0000
[30, 2F] = sector size in multiples of 256-bytes	2F	5E	0020
Erase Sector Region 2 Information	30	60	0000
	31	62	003E
	32	64	0000
	33	66	0000
Erase Sector Region 3 Information	34	68	0001
	35	6A	0000
	36	6C	0000
	37	6E	0000
Erase Sector Region 4 Information	38	70	0000
	39	72	0000
	3A	74	0000
	3B	76	0000
	3C	78	0000

Table 6-4. CFI Mode: Primary Vendor-Specific Extended Query Data Values

Description	Address (h)	Address (h)	Data (h)
	(Word Mode)	(Byte Mode)	
Query-unique ASCII string "PRI"	40	80	0050
	41	82	0052
	42	84	0049
Major version number, ASCII	43	86	0031
Minor version number, ASCII	44	88	0031
Address sensitive unlock (0=required, 1= not required)	45	8A	0000
Erase suspend (2= to read and write)	46	8C	0002
Sector protect (N= # of sectors/group)	47	8E	0004
Temporary sector unprotect (1=supported)	48	90	0001
Sector protect/Chip unprotect scheme	49	92	0004
Simultaneous R/W operation (0=not supported)	4A	94	0000
Burst mode type (0=not supported)	4B	96	0000
Page mode type (0=not supported)	4C	98	0000
ACC (Acceleration) Supply Minimum (0=not supported, D7-D4:Volt, D3-D0:100mV)	4D	9A	00B5
ACC (Acceleration) Supply Maximum (0=not supported, D7-D4:Volt, D3-D0:100mV)	4E	9C	00C5
Top/Bottom Boot Sector Flag 02h=Bottom Boot Device, 03h=Top Boot Device	4F	9E	000X

ABSOLUTE MAXIMUM RATINGS

Storage Temperature	
Plastic Packages	-65°C to +150°C
Ambient Temperature	
with Power Applied.	-65°C to +125°C
Voltage with Respect to Ground	
VCC (Note 1)	-0.5 V to +4.0 V
A9, \overline{OE} , and	
RESET (Note 2)	-0.5 V to +12.5 V
All other pins (Note 1)	-0.5 V to VCC +0.5 V
Output Short Circuit Current (Note 3)	200 mA

Notes:

1. Minimum DC voltage on input or I/O pins is -0.5 V. During voltage transitions, input or I/O pins may overshoot VSS to -2.0 V for periods of up to 20ns. Maximum DC voltage on input or I/O pins is VCC +0.5 V. During voltage transitions, input or I/O pins may overshoot to VCC +2.0 V for periods up to 20 ns.
2. Minimum DC input voltage on pins A9, \overline{OE} , and RESET is -0.5 V. During voltage transitions, A9, \overline{OE} , and RESET may overshoot VSS to -2.0 V for periods of up to 20 ns. Maximum DC input voltage on pin A9 is +12.5 V which may overshoot to 14.0 V for periods up to 20 ns.
3. No more than one output may be shorted to ground at a time. Duration of the short circuit should not be greater than one second.

Stresses above those listed under "Absolute Maximum Ratings" may cause permanent damage to the device. This is a stress rating only; functional operation of the device at these or any other conditions above those indicated in the operational sections of this data sheet is not implied. Exposure of the device to absolute maximum rating conditions for extended periods may affect device reliability.

OPERATING RATINGS**Commercial (C) Devices**Ambient Temperature (T_A) 0°C to +70°C**Industrial (I) Devices**Ambient Temperature (T_A) -40°C to +85°C**V_{CC} Supply Voltages**V_{CC} for full voltage range. +2.7 V to 3.6 V

Operating ranges define those limits between which the functionality of the device is guaranteed.

DC CHARACTERISTICS VCC=2.7V~3.6V

Parameter	Description	Test Conditions	TA=0° C to 70° C			TA=-40° C to 85° C			Unit
			Min	Typ	Max	Min	Typ	Max	
ILI	Input Load Current (Note 1)	VIN = VSS to VCC, VCC = VCC max			±1.0			±1.0	uA
ILIT	A9 Input Load Current	VCC = VCC max, A9=12.5V			35			45	uA
ILO	Output Leakage Current	VOUT = VSS to VCC , VCC = VCC max			±1.0			±1.0	uA
ICC1	VCC Active Read Current (Notes 2, 3)	CE= VIL, 5 MHz		10	16		10	16	mA
		OE = VIH 1 MHz		2	4		2	4	mA
ICC2	VCC Active Write Current (Notes 2, 4, 6)	CE= VIL , OE = VIH, WE=VIL		15	30		15	30	mA
ICC3	VCC Standby Current (Note 2)	CE, RESET, WP/ACC = VCC±0.3V		0.2	15		0.2	15	uA
ICC4	VCC Reset Current (Note 2)	RESET = VSS ± 0.3V, WP/ACC= VCC ± 0.3V		0.2	15		0.2	15	uA
ICC5	Automatic Sleep Mode (Notes 2,5)	VIH = VCC ± 0.3V; VIL = VSS ± 0.3V, WP/ACC=VCC±0.3V		0.2	15		0.2	15	uA
IACC	WP/ACC Accelerated Program Current, Word or Byte	CE=VIL, WP/ACC pin		5	10		5	10	mA
		OE=VIH VCC pin		15	30		15	30	mA
VIL	Input Low Voltage		-0.5		0.8	-0.5		0.8	V
VIH	Input High Voltage		0.7xVcc		Vcc+0.3	0.7xVcc		Vcc+0.3	V
VHH	Voltage for WP/ACC Sector Protect/Unprotect and Program Acceleration	VCC = 3.0 V ± 10%	11.5		12.5	11.5		12.5	V
VID	Voltage for Automatic Select and Temporary Sector Unprotect	VCC = 3.0 V ± 10%	11.5		12.5	11.5		12.5	V
VOL	Output Low Voltage	IOL=4.0mA, VCC=VCC min			0.45			0.45	V
VOH1	Output High Voltage	IOH=-2.0mA, VCC=VCC min	0.85Vcc			0.85Vcc			V
VOH2		IOH=-100uA, VCC = VCC min	Vcc-0.4			Vcc-0.4			V
VLKO	Low VCC Lock-Out Voltage (Note 6)		1.4		2.1	1.4		2.1	V

Notes:

1. On the WP/ACC pin only, the maximum input load current when WP/ACC = VIL is ±5.0uA / VIH is ±3.0uA.
2. Maximum ICC specifications are tested with VCC = VCC max.
3. The ICC current listed is typically is less than 2 mA/MHz, with OE at VIH. Typical specifications are for VCC = 3.0V.
4. ICC active while Embedded Erase or Embedded Program is in progress.
5. Automatic sleep mode enables the low power mode when addresses remain stable for tACC + 30 ns. Typical sleep mode current is 200 nA.
6. Not 100% tested.

SWITCHING TEST CIRCUITS

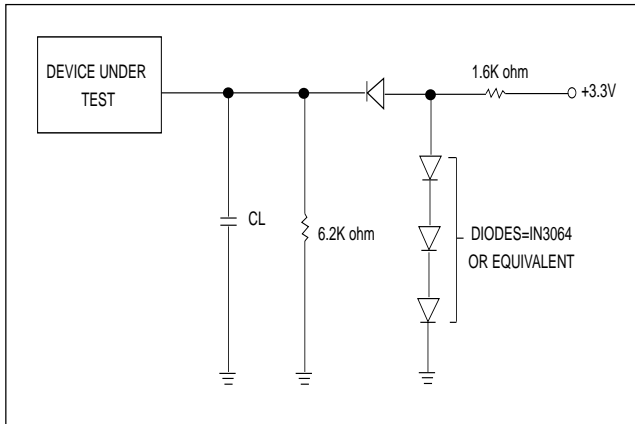

TEST SPECIFICATIONS

Test Condition	70	90	Unit
Output Load	1 TTL gate		
Output Load Capacitance, CL (including jig capacitance)	30	100	pF
Input Rise and Fall Times	5		ns
Input Pulse Levels	0.0-3.0		V
Input timing measurement reference levels	1.5		V
Output timing measurement reference levels	1.5		V

KEY TO SWITCHING WAVEFORMS

WAVEFORM	INPUTS	OUTPUTS
	Steady	
	Changing from H to L	
	Changing from L to H	
	Don't Care, Any Change Permitted	Changing, State Unknown
	Does Not Apply	Center Line is High Impedance State(High Z)

SWITCHING TEST WAVEFORMS

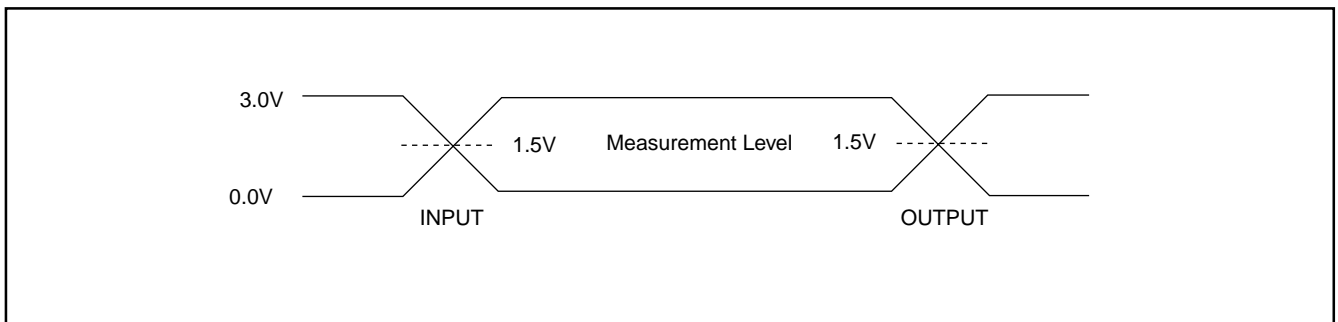

AC CHARACTERISTICS TA=-40° C to 85° C, VCC=2.7V~3.6V

Symbol	DESCRIPTION	CONDITION	70	90	Unit
tACC	Address to output delay	$\overline{CE}=VIL$ $\overline{OE}=VIL$	MAX 70	90	ns
tCE	Chip enable to output delay	$\overline{OE}=VIL$	MAX 70	90	ns
tOE	Output enable to output delay		MAX 40	40	ns
tDF	\overline{OE} High to output float(Note1)		MAX 30	30	ns
tOH	Output hold time of from the rising edge of Address, \overline{CE} or \overline{OE} whichever happens first		MIN 0	0	ns
tRC	Read cycle time (Note 1)		MIN 70	90	ns
tWC	Write cycle time (Note 1)		MIN 70	90	ns
tCWC	Command write cycle time(Note 1)		MIN 70	90	ns
tAS	Address setup time		MIN 0	0	ns
tAH	Address hold time		MIN 45	45	ns
tDS	Data setup time		MIN 45	45	ns
tDH	Data hold time		MIN 0	0	ns
tVCS	Vcc setup time(Note 1)		MIN 50	50	ns
tCS	Chip enable setup time		MIN 0	0	ns
tCH	Chip enable hold time		MIN 0	0	ns
tOES	Output enable setup time (Note 1)		MIN 0	0	ns
tOEH	Output enable hold time (Note 1)	Read	MIN 0	0	ns
		Toggle & Data Polling	MIN 10	10	ns
tWES	\overline{WE} setup time		MIN 0	0	ns
tWEH	\overline{WE} hold time		MIN 0	0	ns
tCEP	\overline{CE} pulse width		MIN 45	45	ns
tCEPH	\overline{CE} pulse width high		MIN 30	30	ns
tWP	\overline{WE} pulse width		MIN 45	45	ns
tWPH	\overline{WE} pulse width high		MIN 30	30	ns
tBUSY	Program/Erase valid to RY/BY delay		MAX 90	90	ns
tGHWL	Read recovery time before write		MIN 0	0	ns
tGHEL	Read recovery time before write		MIN 0	0	ns
tWHWH1	Programming operation	BYTE	TYP 9	9	us
		WORD	TYP 11	11	us
	Accelerated programming operation word or byte	TYP 7	7	us	
tWHWH2	Sector erase operation		TYP 0.9	0.9	sec
tBAL	Sector address hold time		MAX 50	50	us

Note: 1.Not 100% Tested
2.tr = tf = 5ns

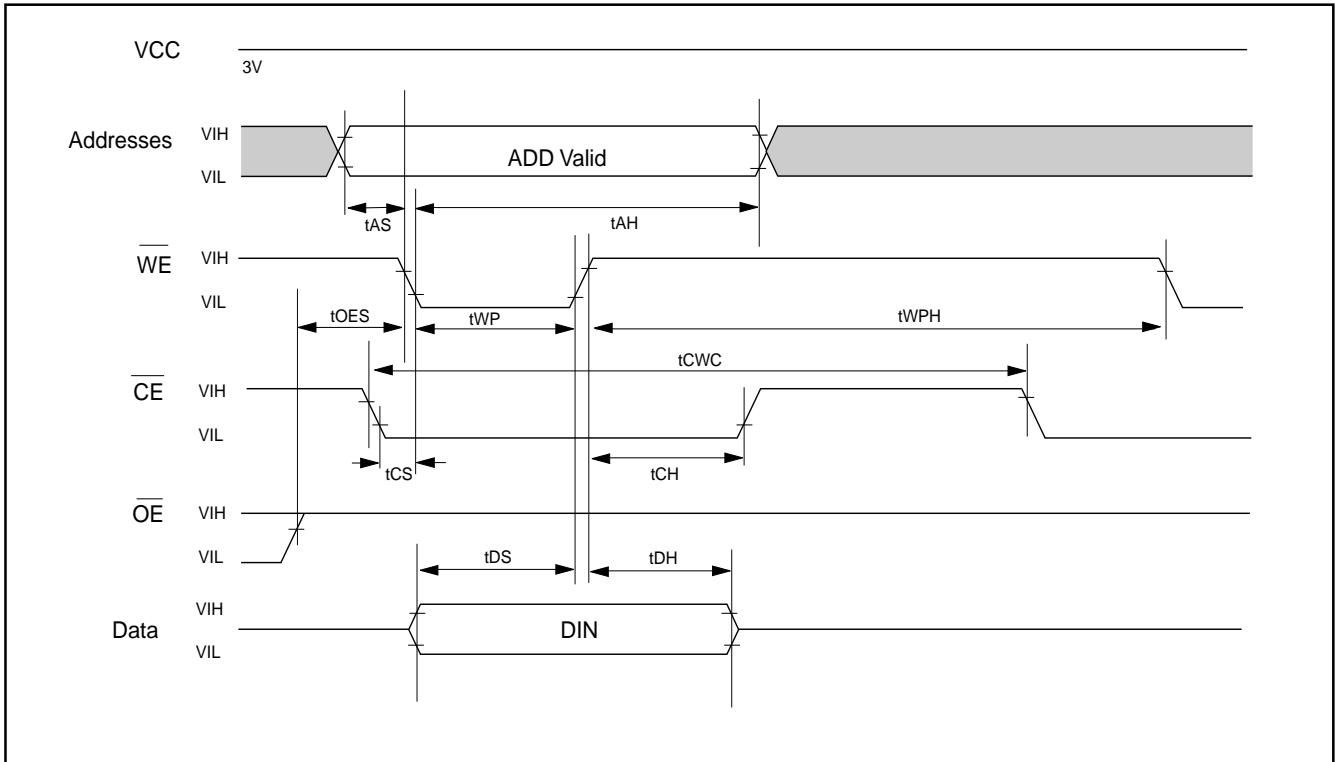
Fig 1. COMMAND WRITE OPERATION

READ/RESET OPERATION

Fig 2. READ TIMING WAVEFORMS

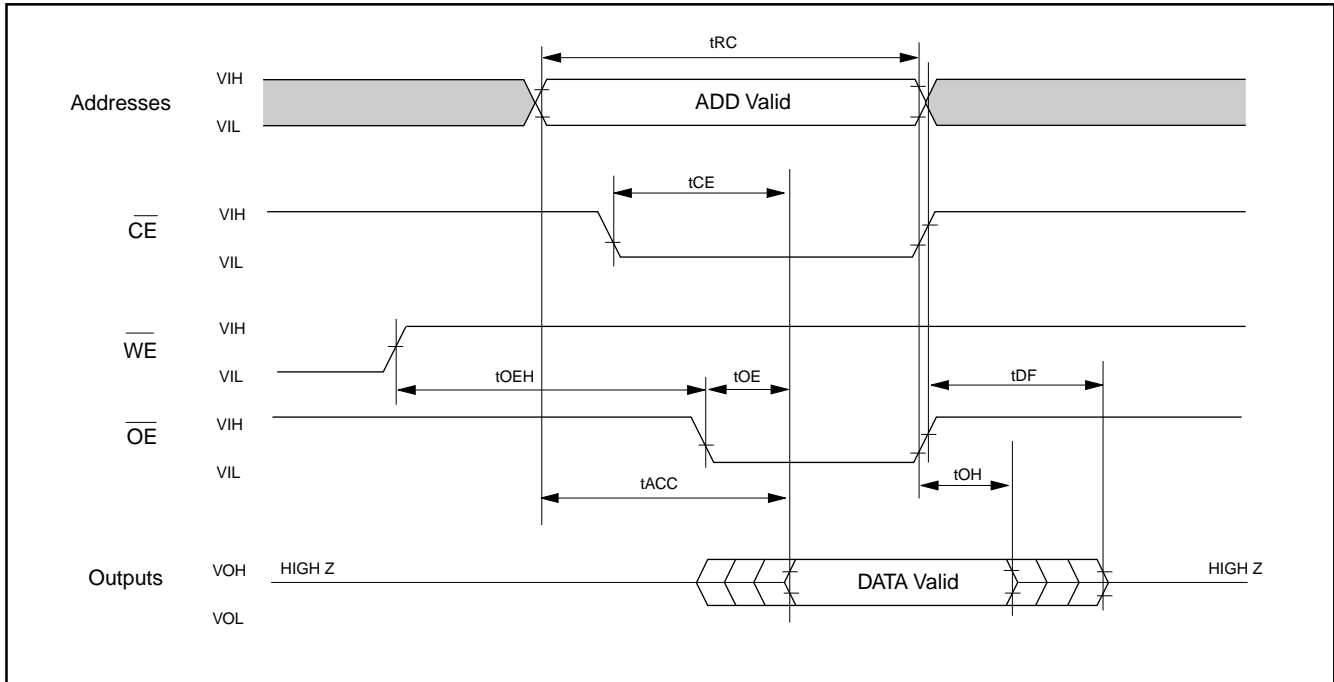

AC CHARACTERISTICS

Parameter	Description	Test Setup	All Speed Options	Unit
tREADY1	RESET PIN Low (During Automatic Algorithms) to Read or Write (See Note)	MAX	20	us
tREADY2	RESET PIN Low (NOT During Automatic Algorithms) to Read or Write (See Note)	MAX	500	ns
tRP1	RESET Pulse Width (During Automatic Algorithms)	MIN	10	us
tRP2	RESET Pulse Width (NOT During Automatic Algorithms)	MIN	500	ns
tRH	RESET High Time Before Read(See Note)	MIN	70	ns
tRB1	RY/BY Recovery Time(to CE, OE go low)	MIN	0	ns
tRB2	RY/BY Recovery Time(to WE go low)	MIN	50	ns

Note:Not 100% tested

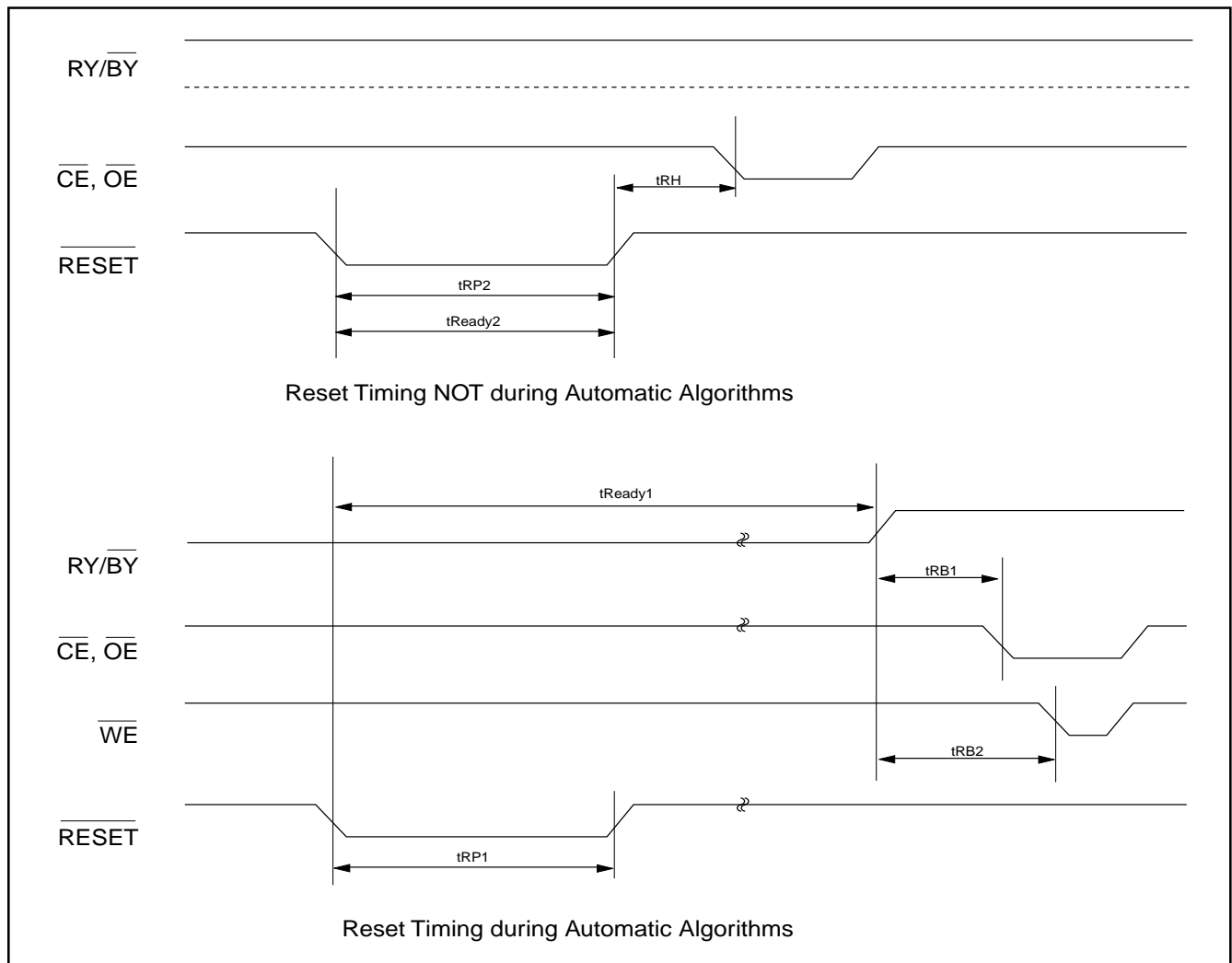
Fig 3. RESET TIMING WAVEFORM

ERASE/PROGRAM OPERATION
Fig 4. AUTOMATIC CHIP ERASE TIMING WAVEFORM

Fig 5. AUTOMATIC CHIP ERASE ALGORITHM FLOWCHART

Fig 6. AUTOMATIC SECTOR ERASE TIMING WAVEFORM

Fig 7. AUTOMATIC SECTOR ERASE ALGORITHM FLOWCHART

Fig 8. ERASE SUSPEND/RESUME FLOWCHART

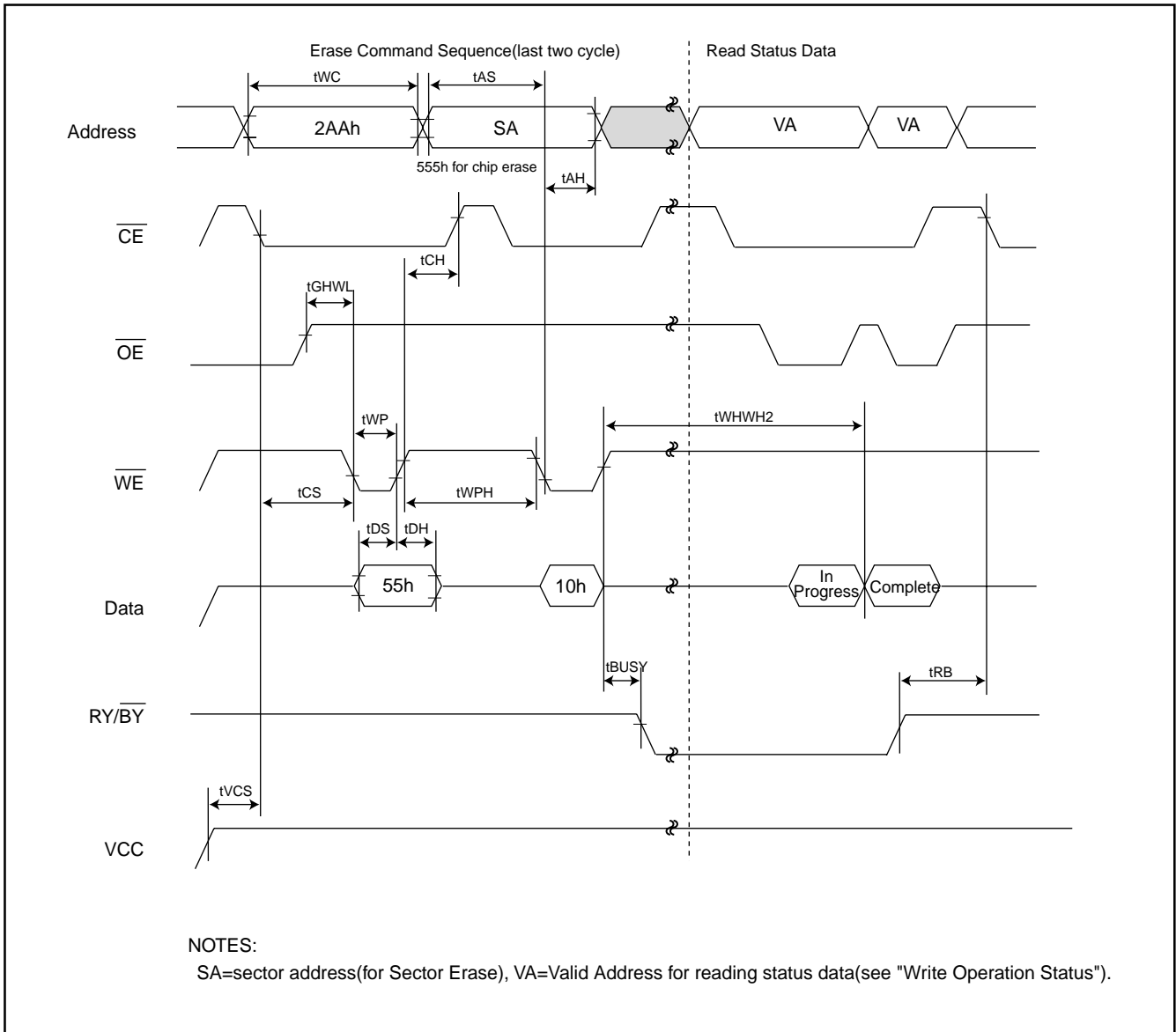
Fig 9. AUTOMATIC PROGRAM TIMING WAVEFORMS

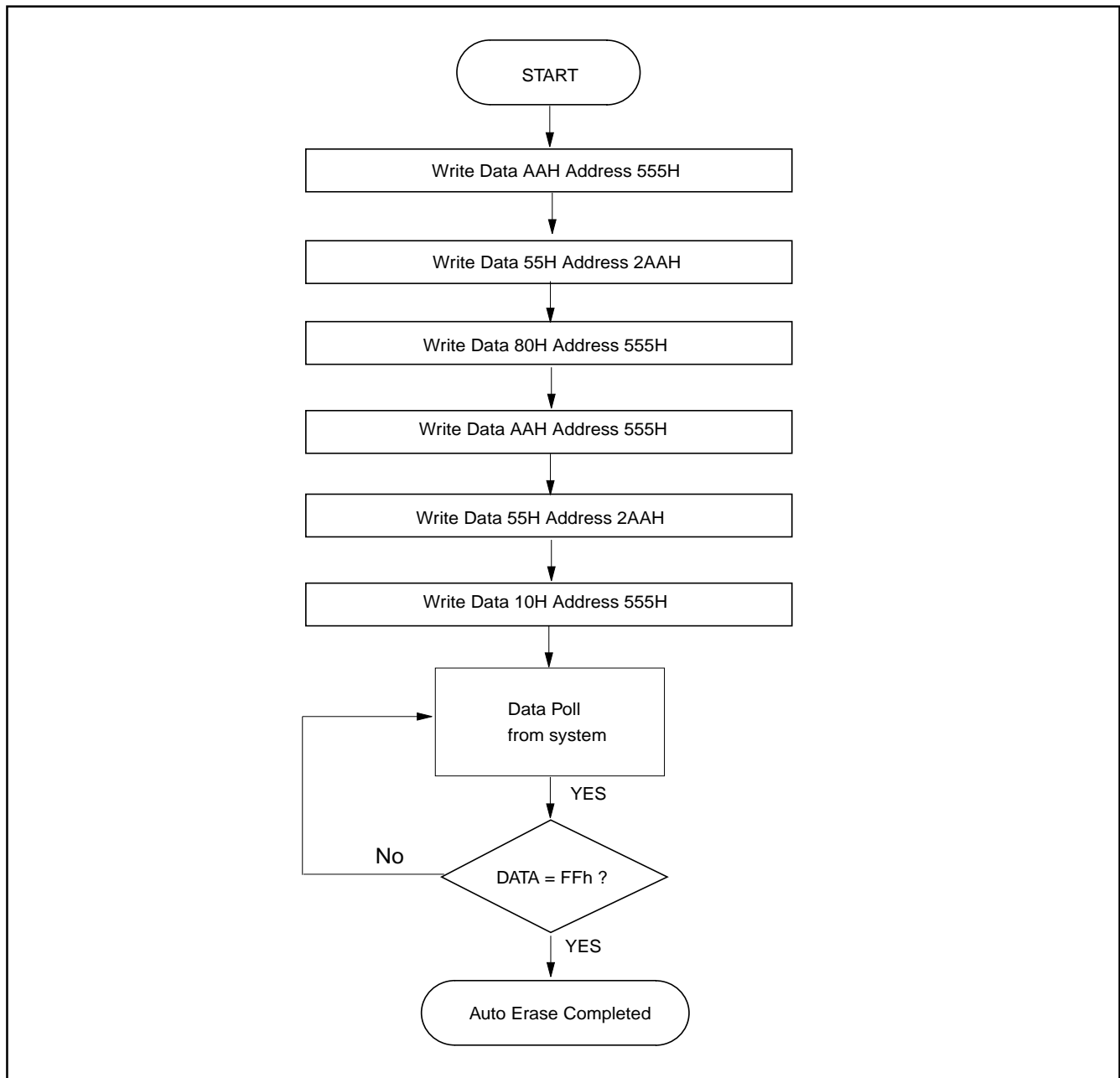
Fig 10. Accelerated Program Timing Diagram

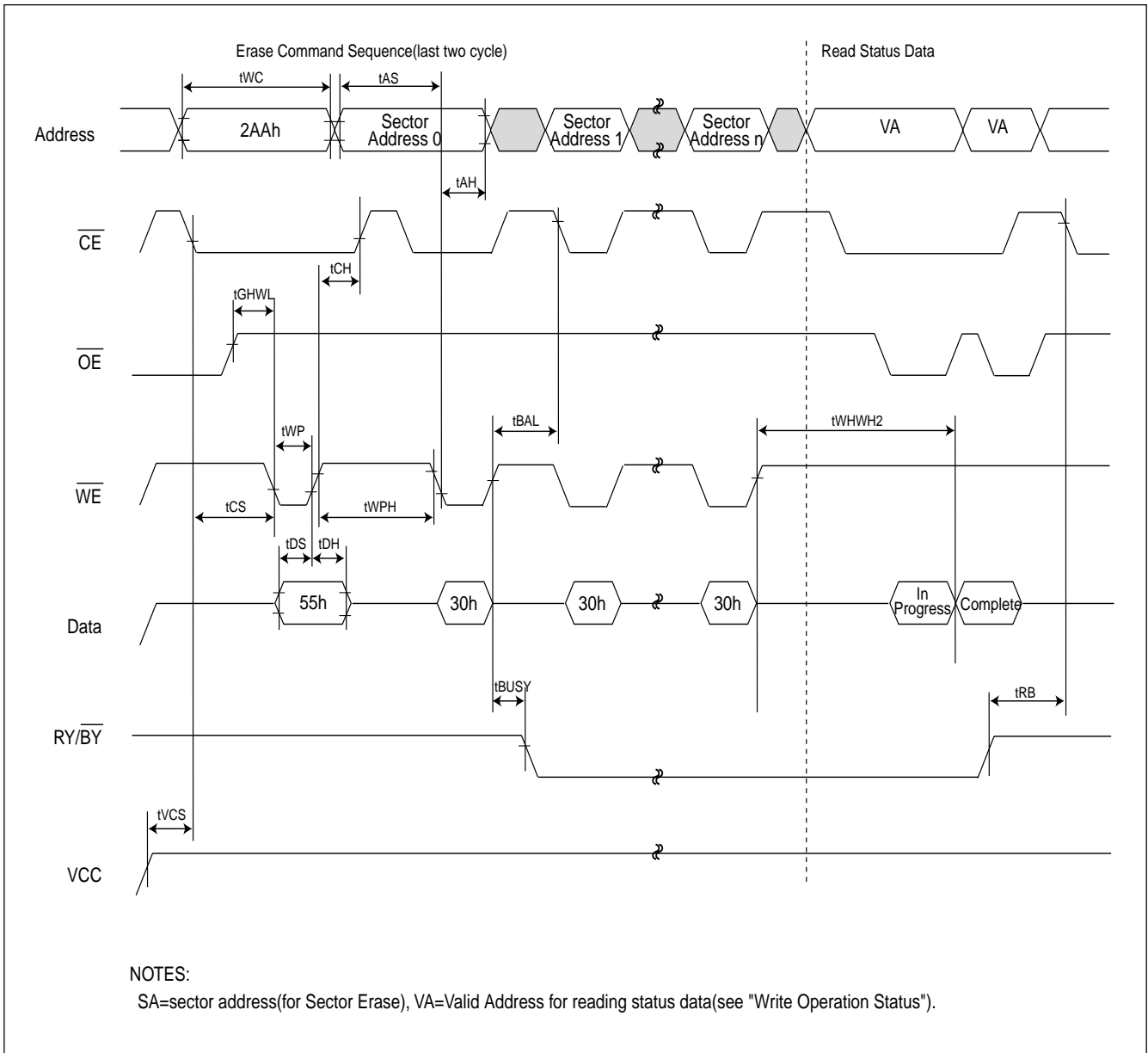
Fig 11. CE CONTROLLED WRITE TIMING WAVEFORM

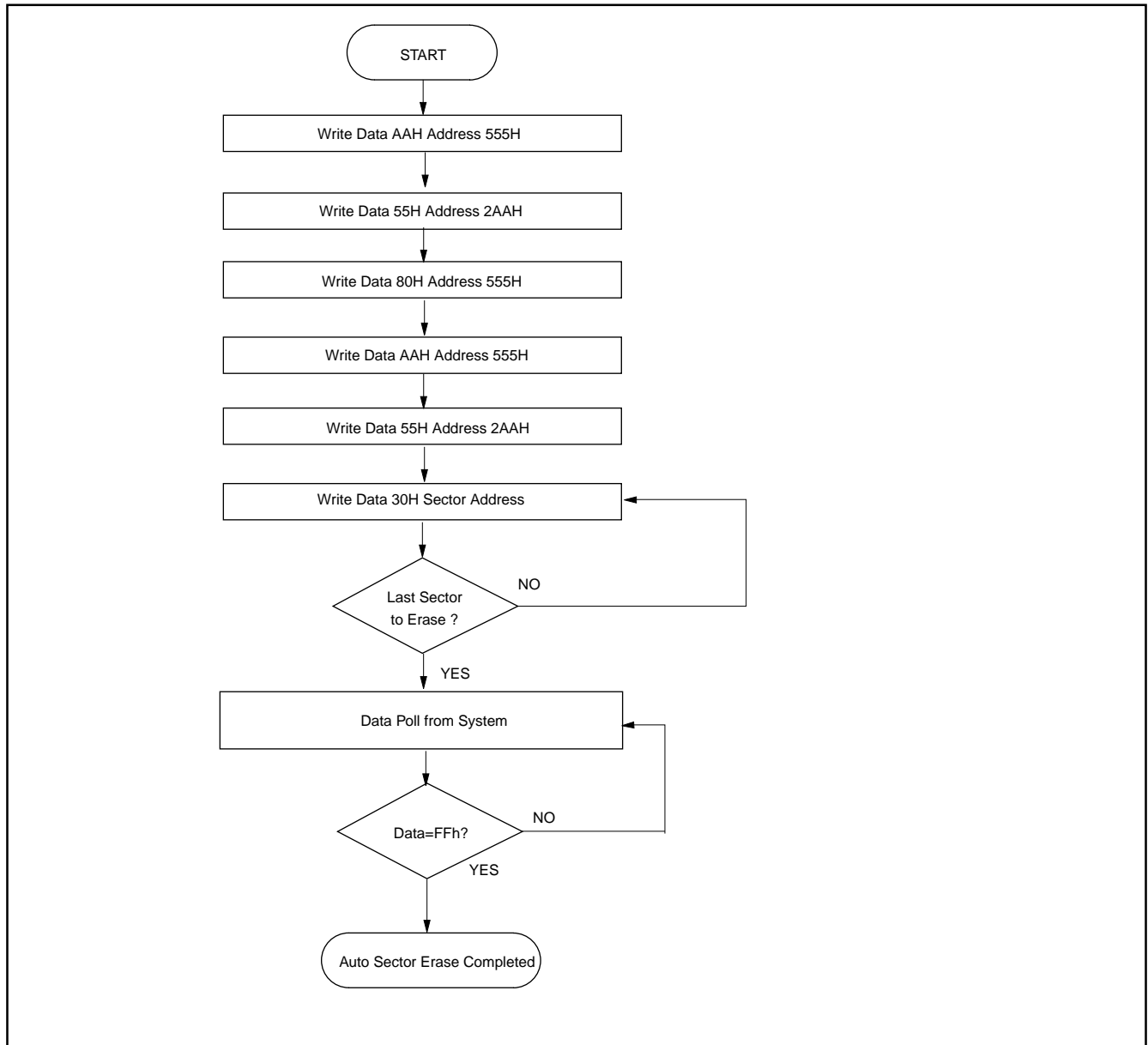
Fig 12. AUTOMATIC PROGRAMMING ALGORITHM FLOWCHART

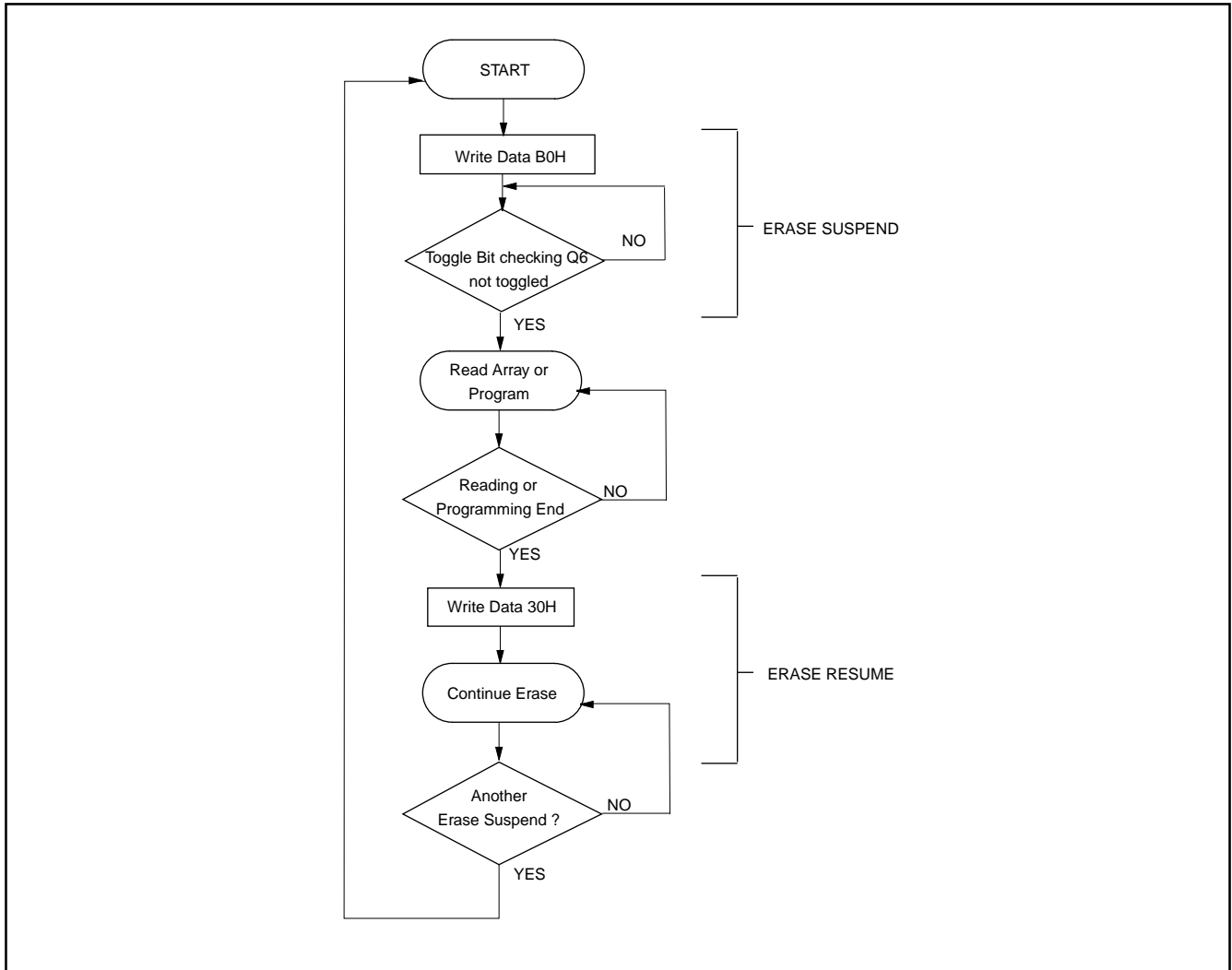
SECTOR GROUP PROTECT/CHIP UNPROTECT
Fig 13. Sector Group Protect/Chip Unprotect Waveform (RESET Control)

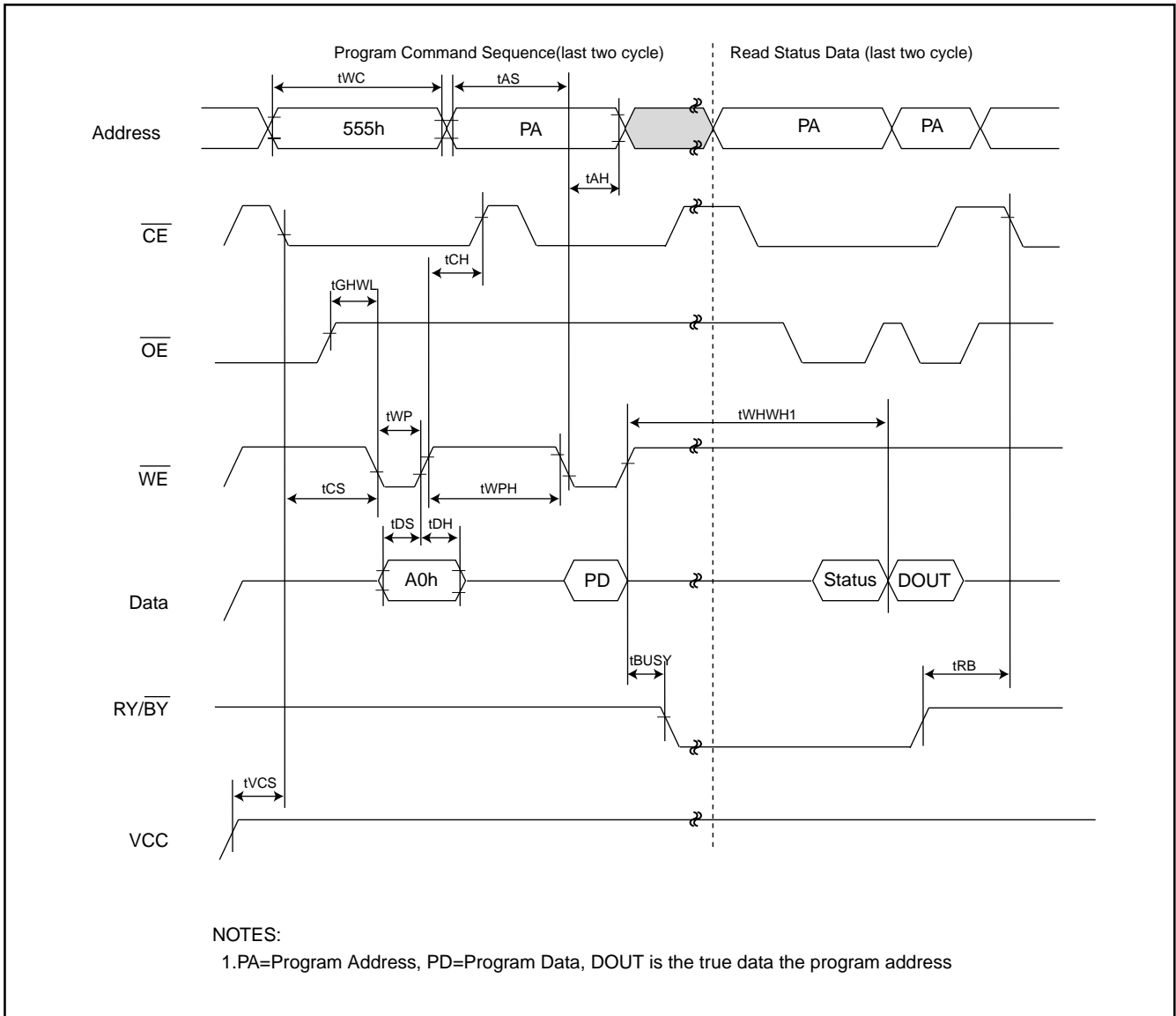
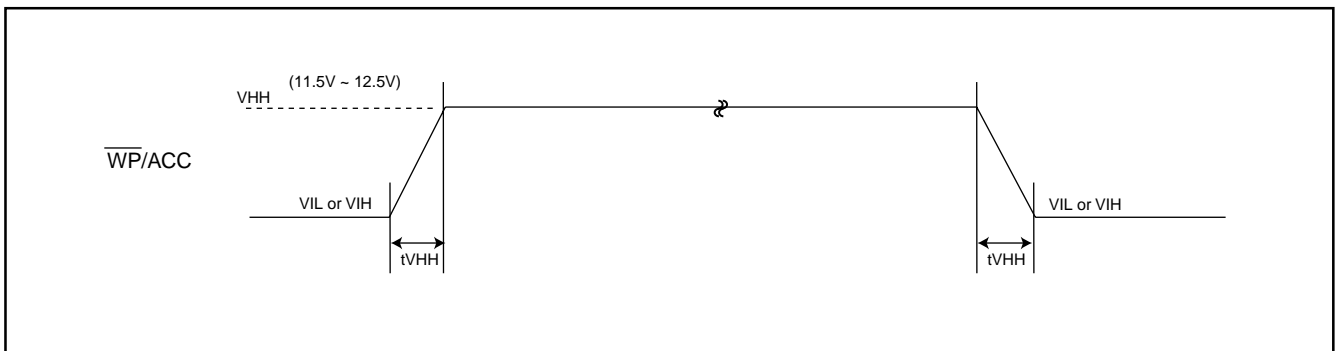
Note:

1. For sector group protect A6=0, A1=1, A0=0 ; for chip unprotect A6=1, A1=1, A0=0

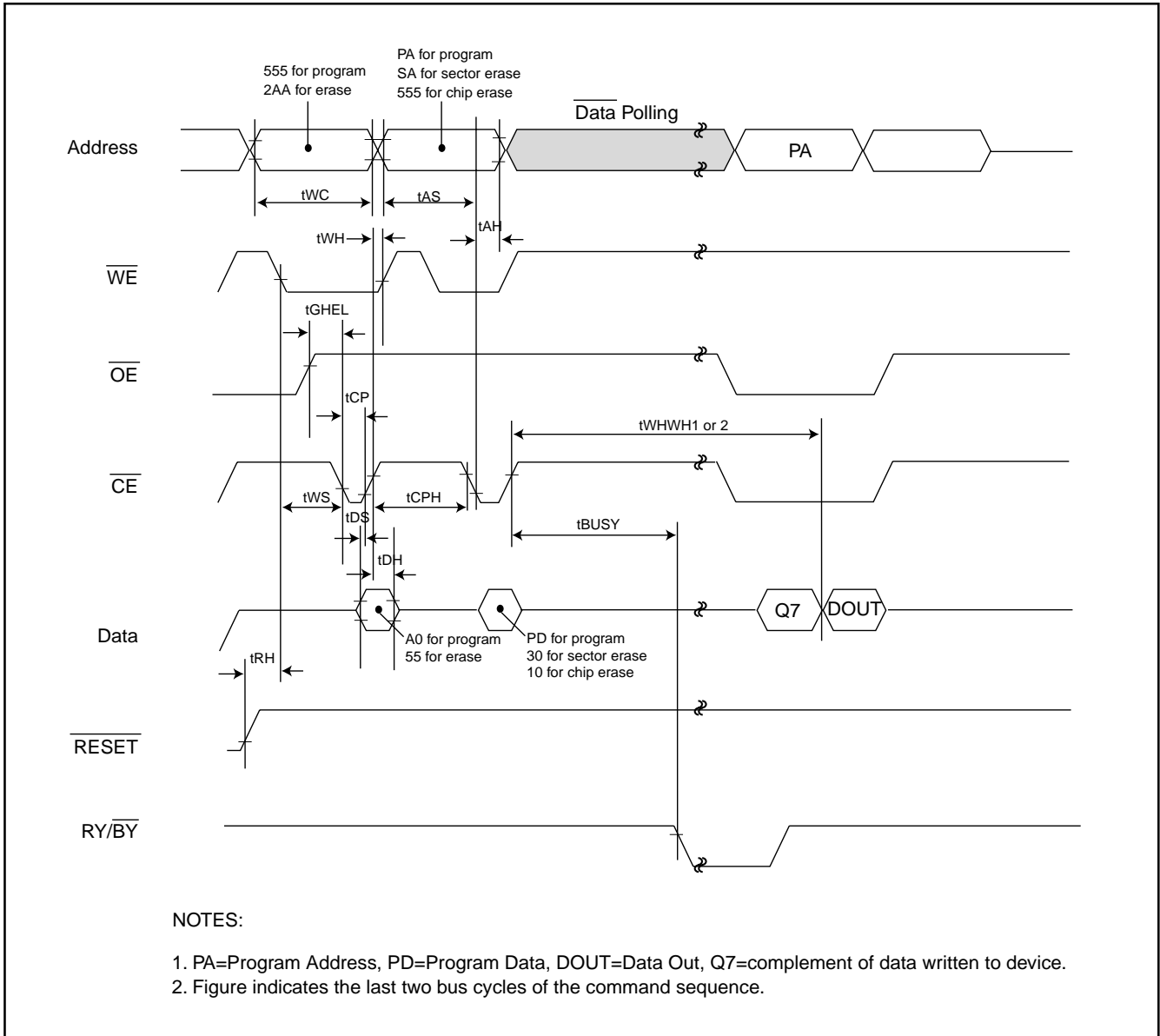
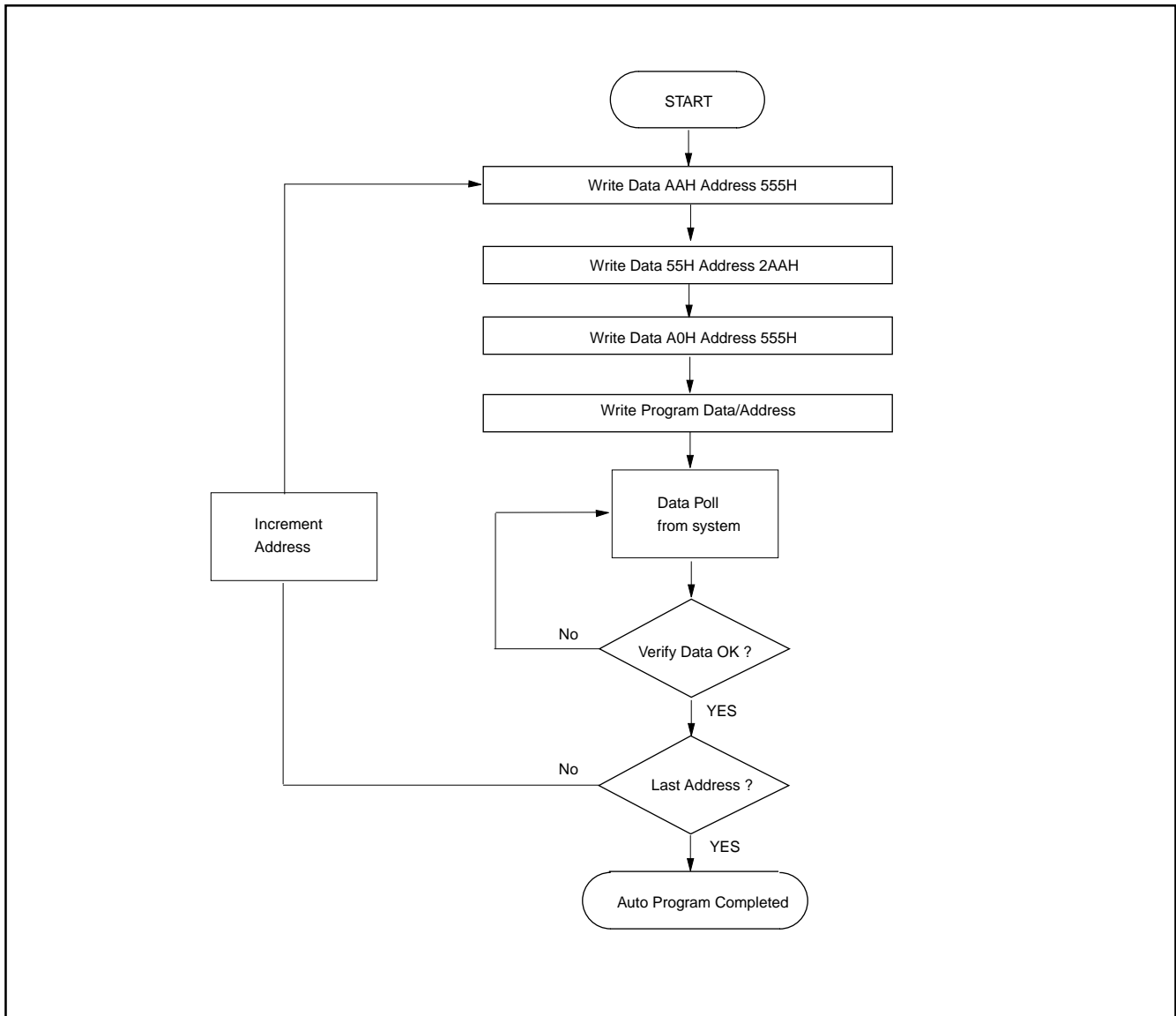
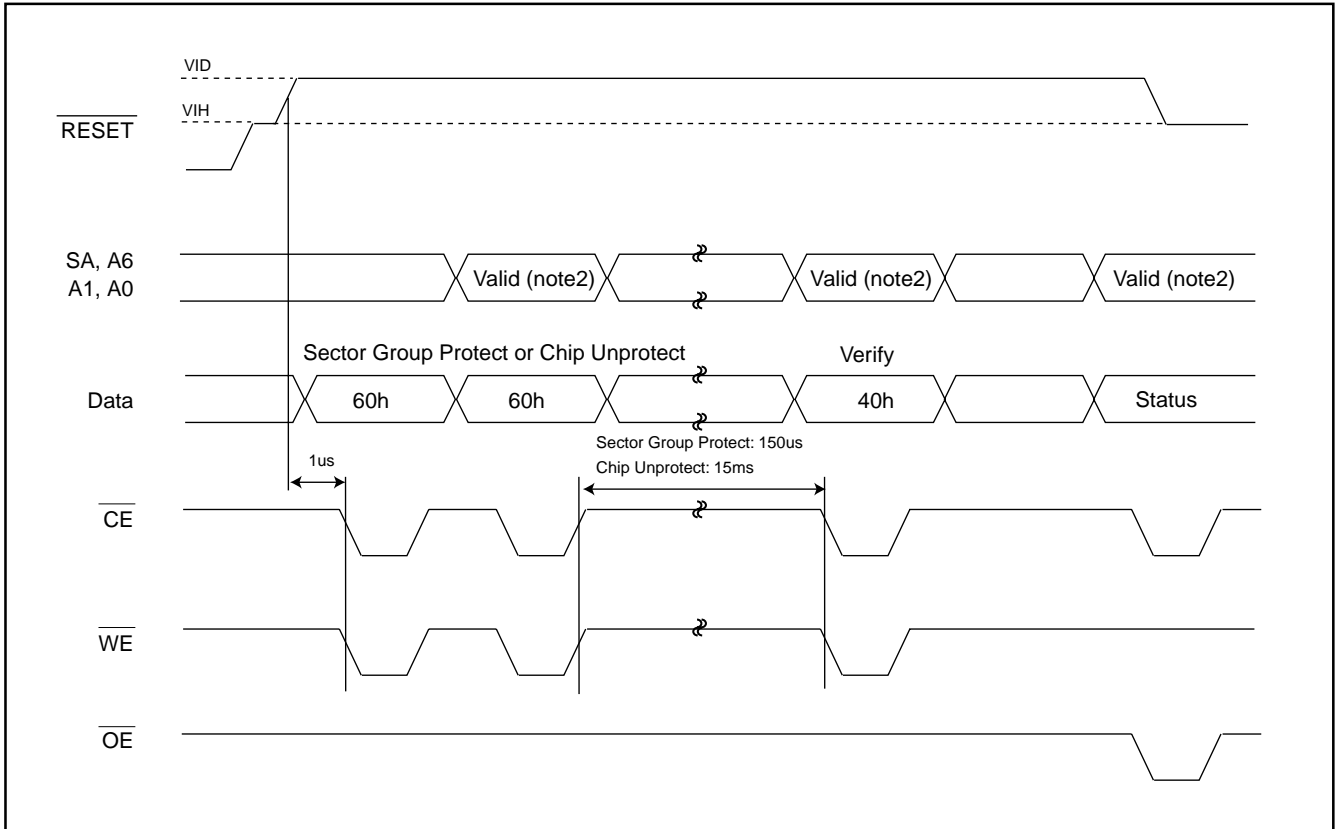
Fig 14. IN-SYSTEM SECTOR GROUP PROTECT/CHIP UNPROTECT ALGORITHMS WITH $\overline{\text{RESET}}=\text{VID}$

Table 7. TEMPORARY SECTOR GROUP UNPROTECT

Parameter	Std.	Description	Test Setup	All Speed Options	Unit
tVIDR		VID Rise and Fall Time (See Note)	Min	500	ns
tRSP		RESET Setup Time for Temporary Sector Unprotect	Min	4	us

Note:
Not 100% tested

Fig 15. TEMPORARY SECTOR GROUP UNPROTECT WAVEFORMS

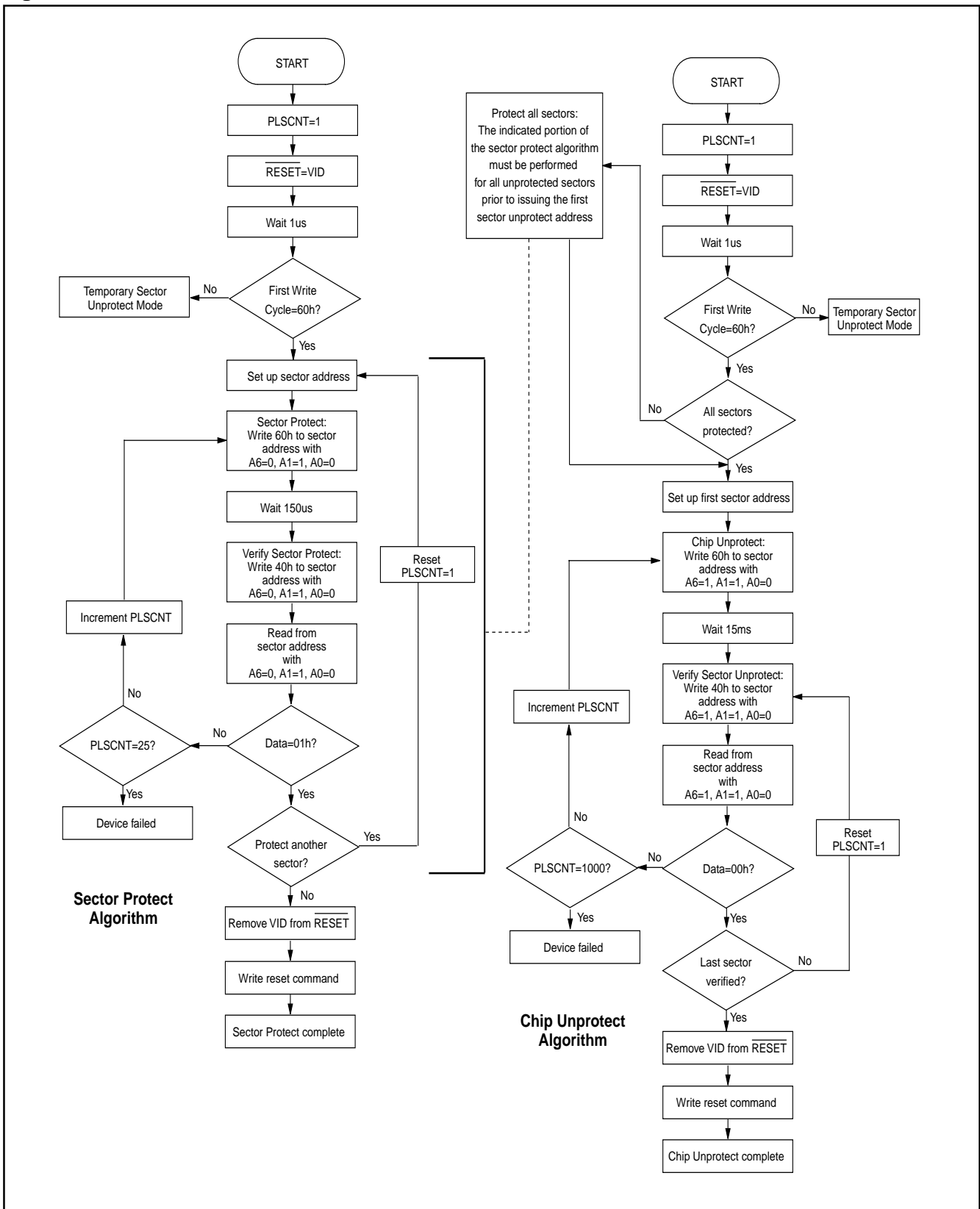
Fig 16. TEMPORARY SECTOR GROUP UNPROTECT FLOWCHART

Fig 17. SILICON ID READ TIMING WAVEFORM

WRITE OPERATION STATUS
Fig 18. DATA POLLING TIMING WAVEFORMS (DURING AUTOMATIC ALGORITHMS)

Fig 19. Data Polling Algorithm**Notes:**

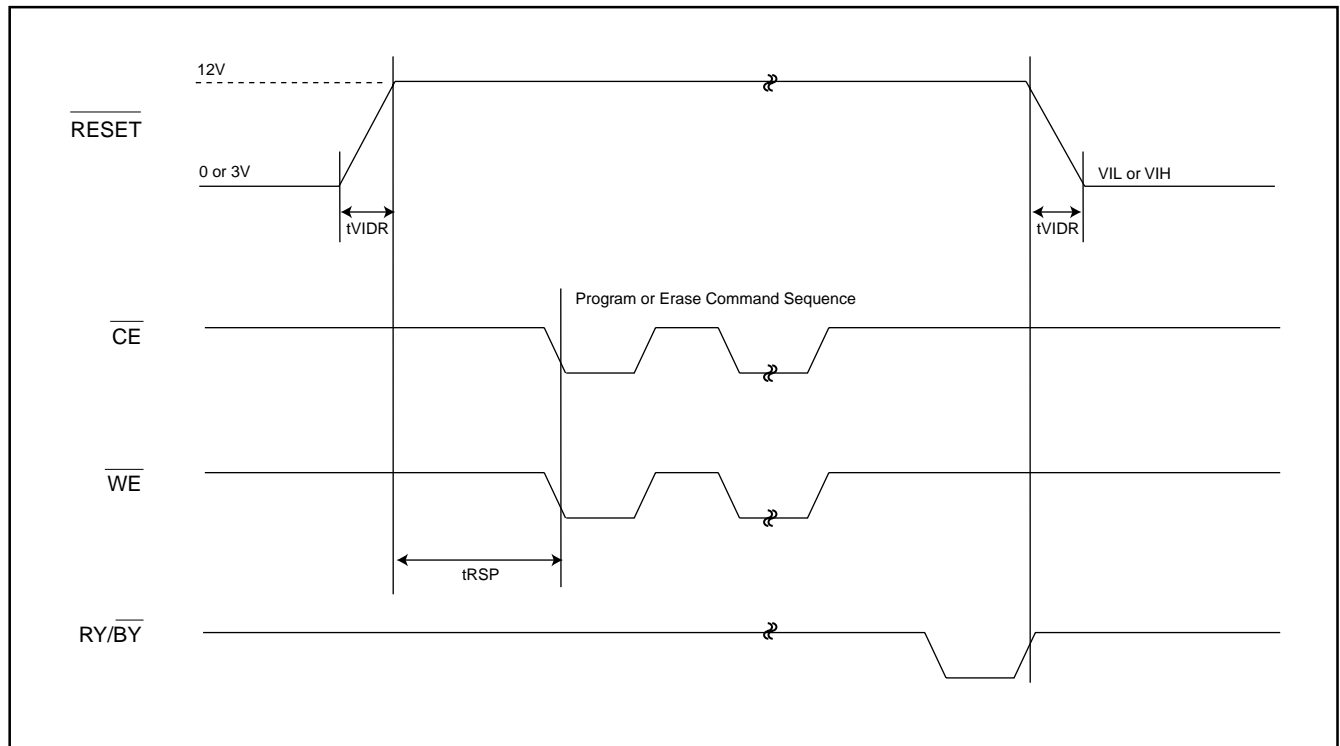
1. VA=valid address for programming or erasure.
2. Q7 should be rechecked even Q5="1" because Q7 may change simultaneously with Q5.

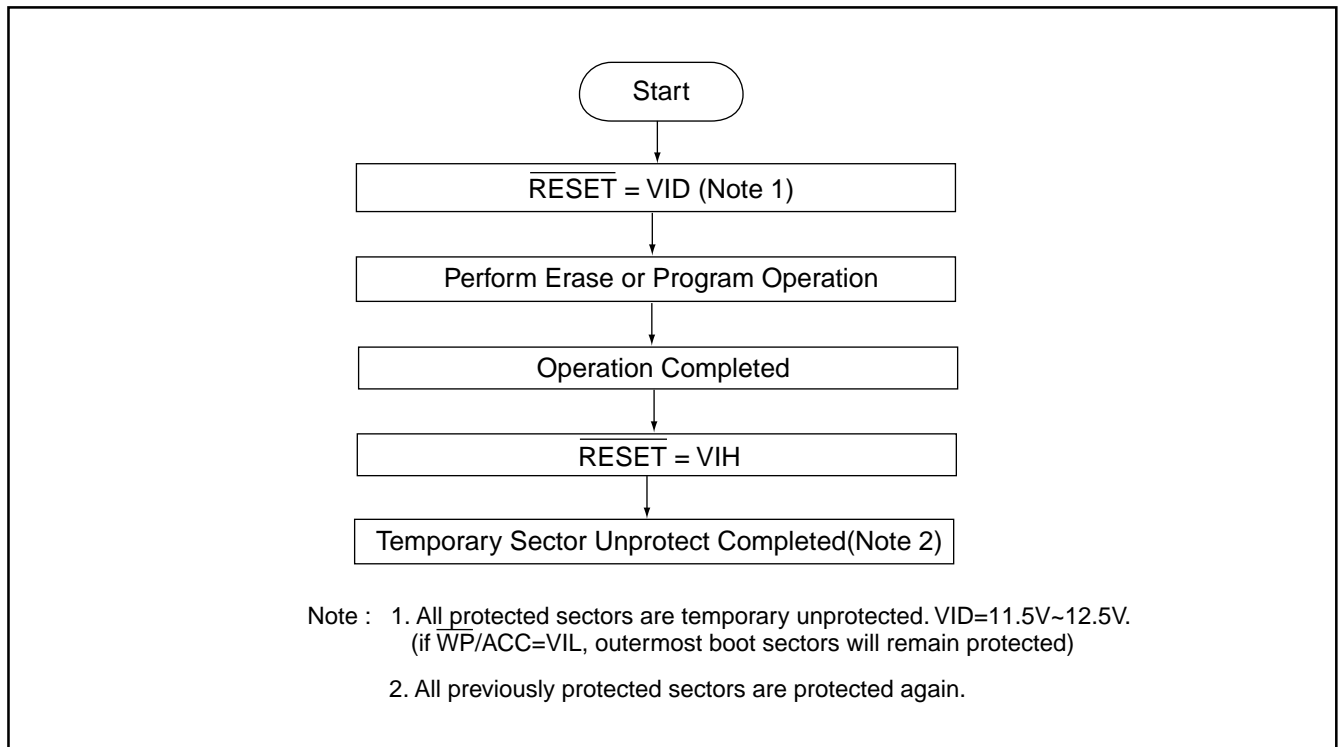
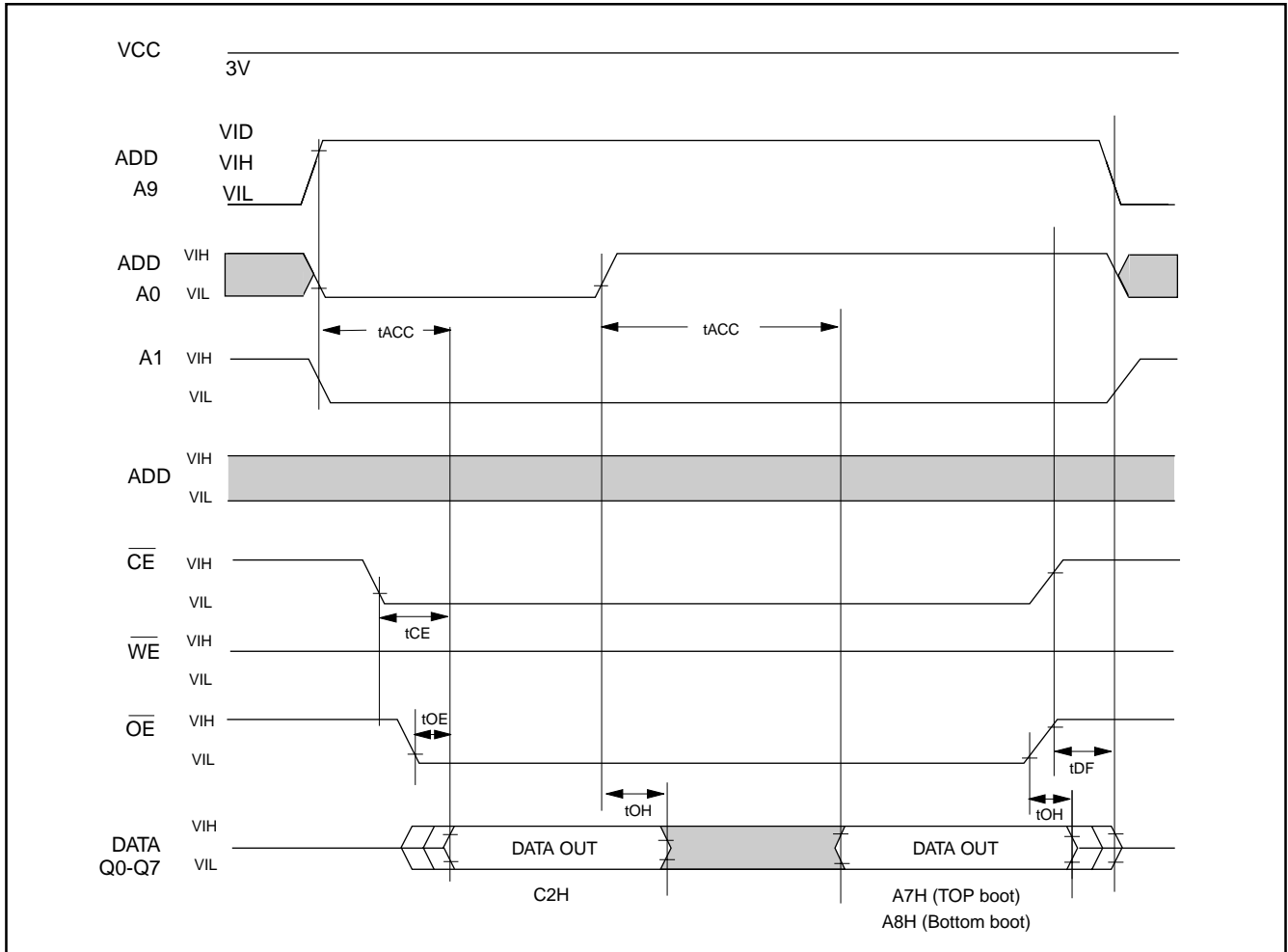
Fig 20. TOGGLE BIT TIMING WAVEFORMS (DURING AUTOMATIC ALGORITHMS)

Fig 21. Toggle Bit Algorithm

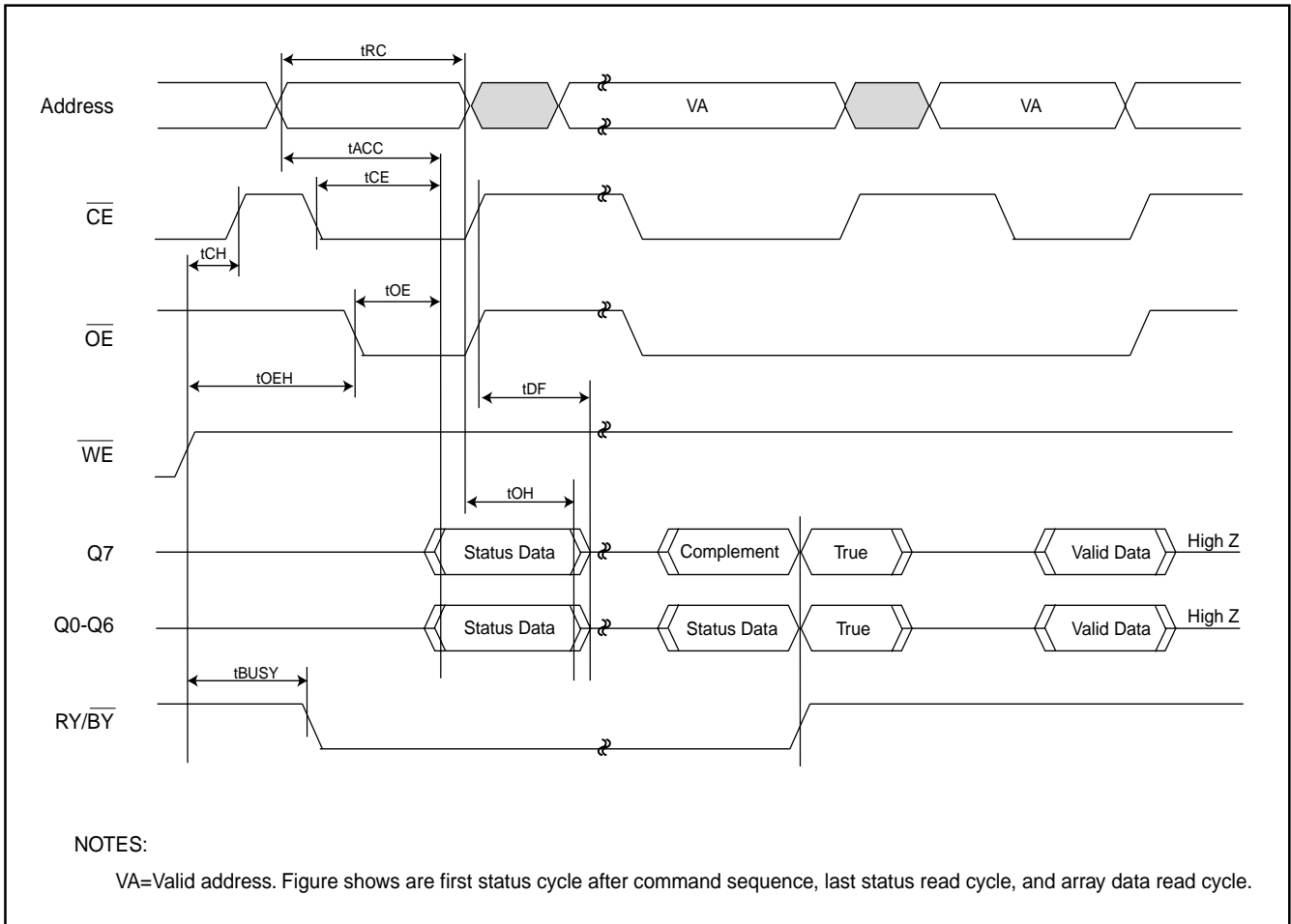
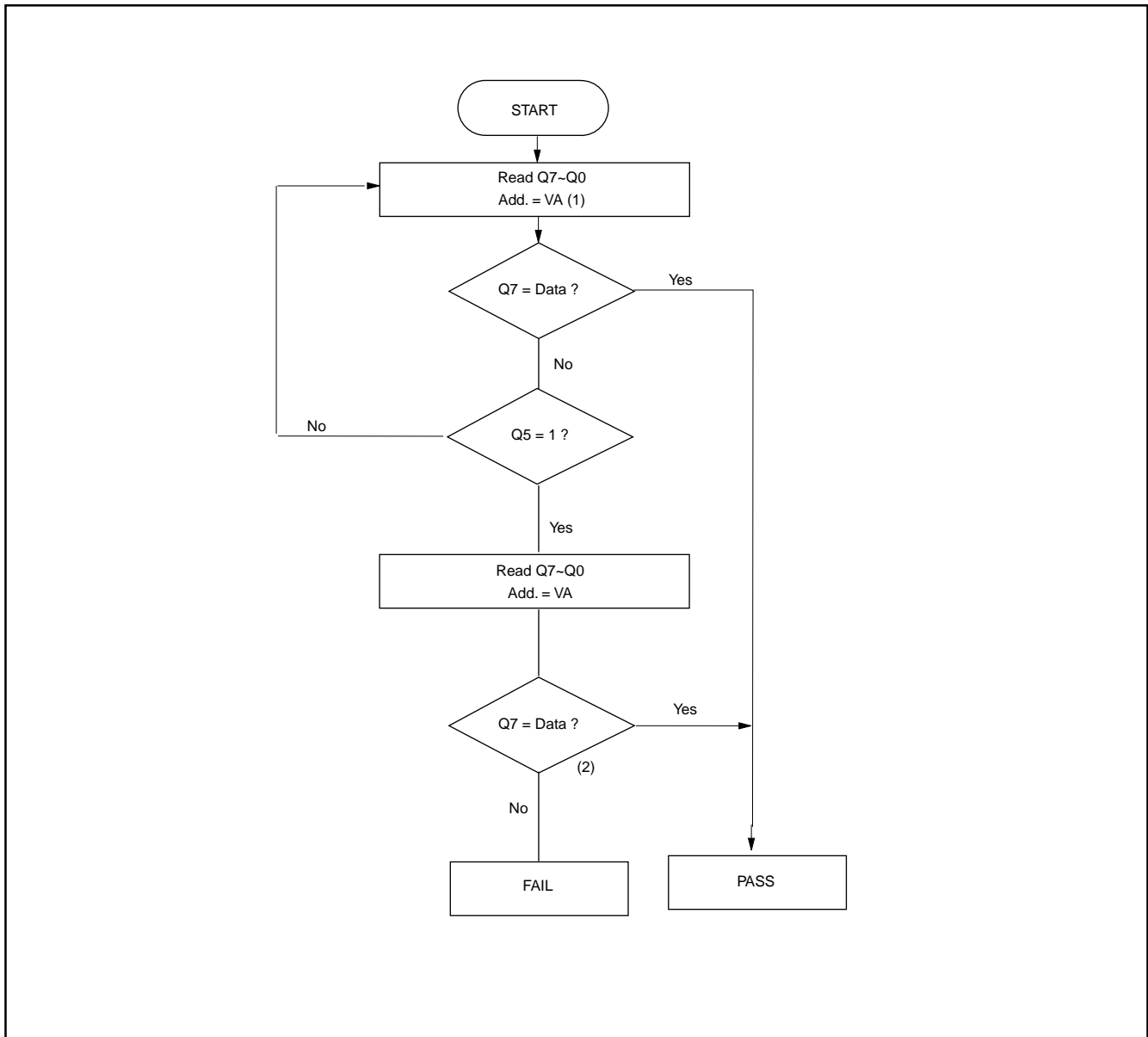
Note:

1. Read toggle bit twice to determine whether or not it is toggling.
2. Recheck toggle bit because it may stop toggling as Q5 changes to "1".

Fig 22. Q6 versus Q2

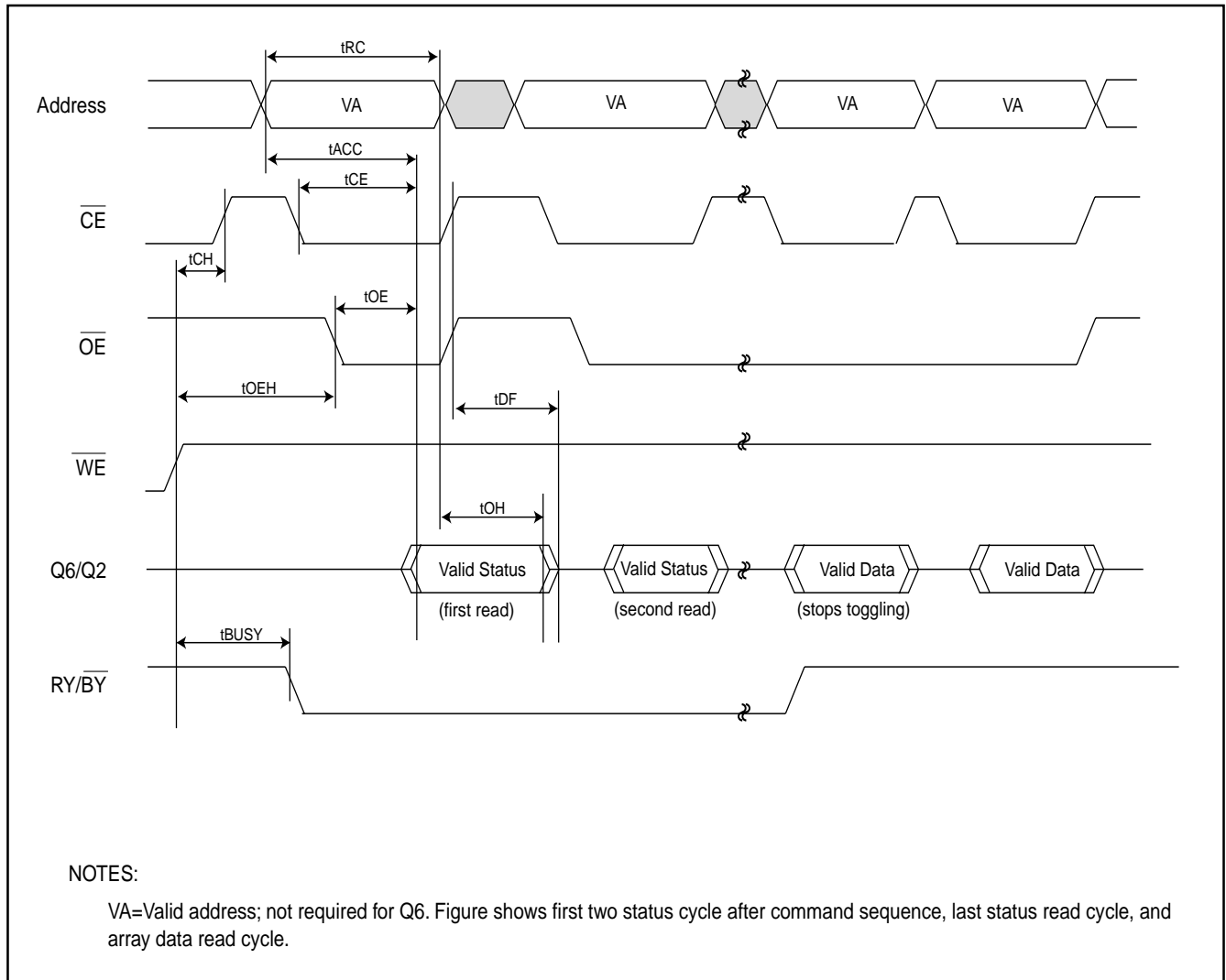
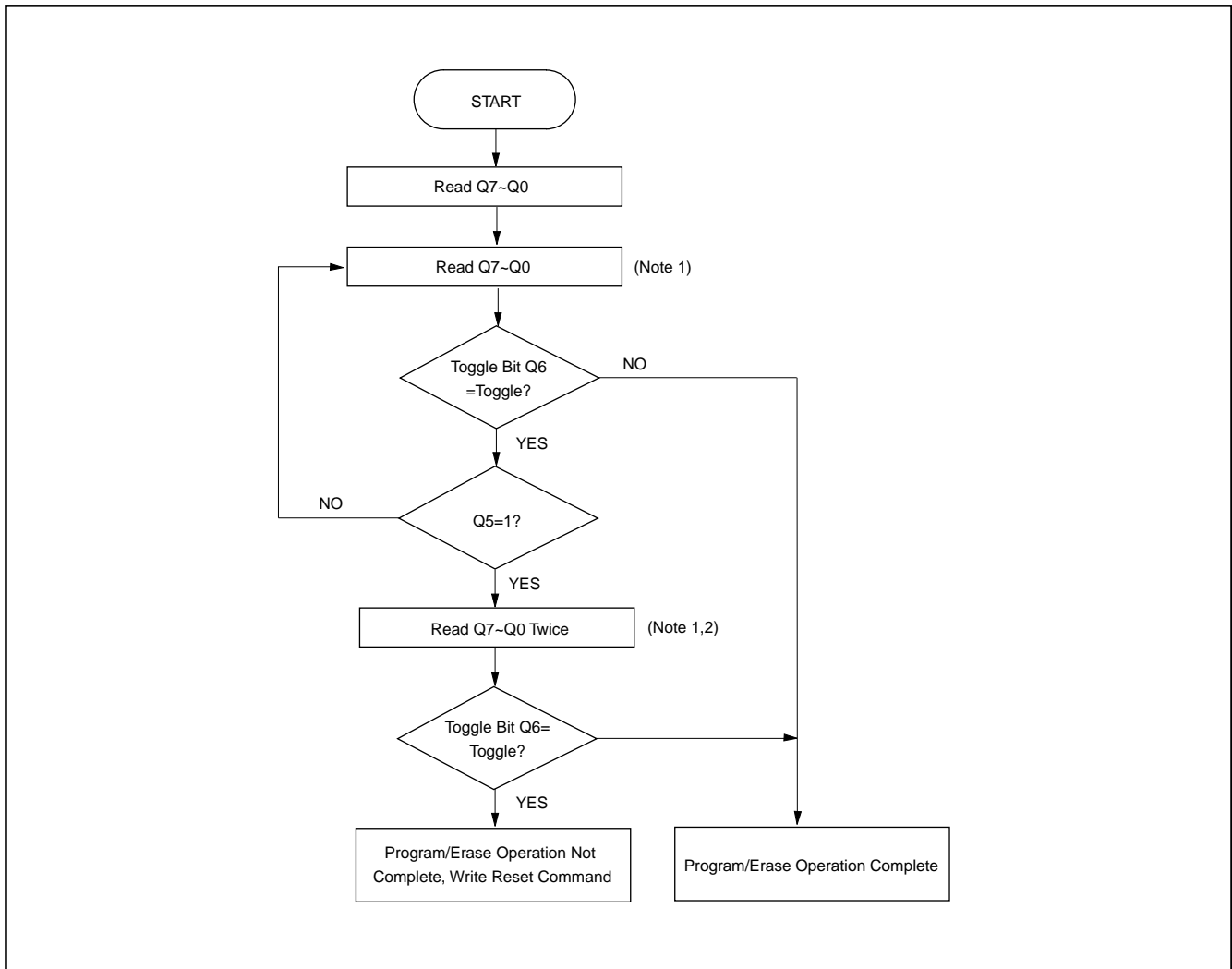
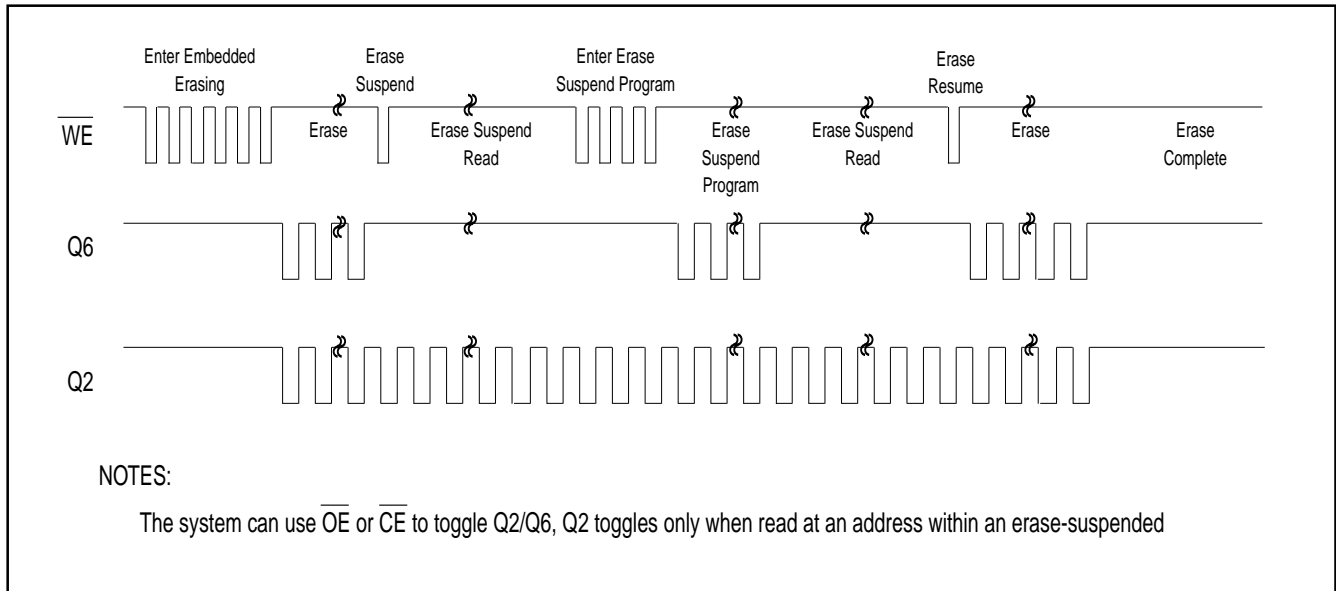
AC CHARACTERISTICS
WORD/BYTE CONFIGURATION (BYTE)

Parameter		Description		Speed Options		Unit
JEDEC	Std			-70	-90	
	tELFL/tELFH	CE to BYTE Switching Low or High	Max	5		ns
	tFLQZ	BYTE Switching Low to Output HIGH Z	Max	25	30	ns
	tFHQV	BYTE Switching High to Output Active	Min	70	90	ns

Figure 23. BYTE TIMING WAVEFORM FOR READ OPERATIONS (BYTE switching from byte mode to word mode)

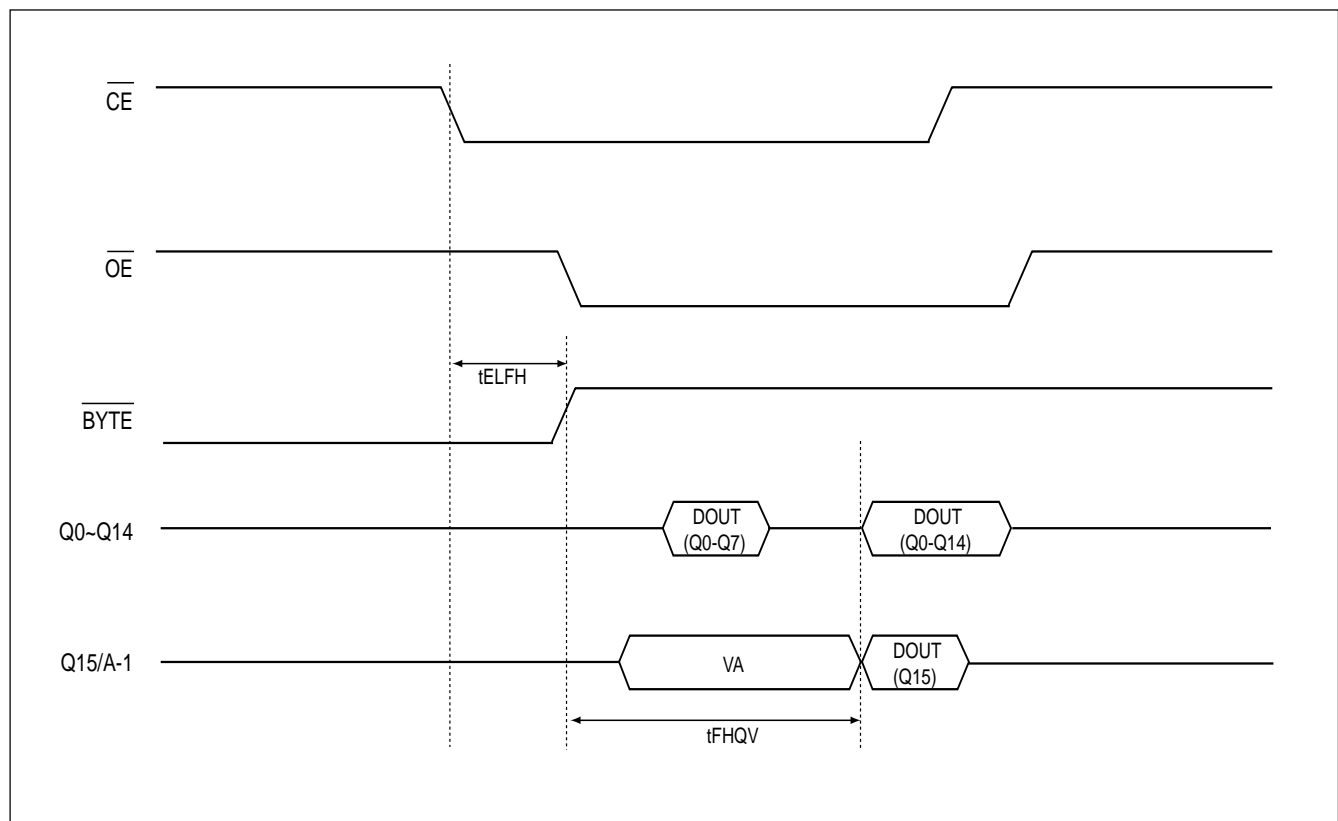

ERASE AND PROGRAMMING PERFORMANCE(1)

PARAMETER	LIMITS			UNITS
	MIN.	TYP.(2)	MAX.	
Sector Erase Time		0.9	15	sec
Chip Erase Time		35	50	sec
Byte Programming Time		9	300	us
Word Program Time		11	360	us
Chip Programming Time	Byte Mode	36	108	sec
	Word Mode	24	72	sec
Accelerated Byte/Word Program Time		7	210	us
Erase/Program Cycles	100,000			Cycles

Note: 1. Not 100% Tested, Excludes external system level over head.
 2. Typical values measured at 25° C, 3.3V.

LATCH-UP CHARACTERISTICS

	MIN.	MAX.
Input Voltage with respect to GND on all pins except I/O pins	-1.0V	12.5V
Input Voltage with respect to GND on all I/O pins	-1.0V	V _{cc} + 1.0V
VCC Current	-100mA	+100mA
Includes all pins except V _{cc} . Test conditions: V _{cc} = 3.0V, one pin at a time.		

TSOP PIN CAPACITANCE

Parameter Symbol	Parameter Description	Test Set	TYP	MAX	UNIT
CIN	Input Capacitance	VIN=0	6	7.5	pF
COUT	Output Capacitance	VOUT=0	8.5	12	pF
CIN2	Control Pin Capacitance	VIN=0	7.5	9	pF

Notes:

1. Sampled, not 100% tested.
2. Test conditions TA=25° C, f=1.0MHz

ORDERING INFORMATION
PLASTIC PACKAGE

PART NO.	ACCESS TIME (ns)	Ball Pitch/ Ball Size	PACKAGE	Remark
MX29LV320ATTC-70	70	-	48 Pin TSOP	
MX29LV320ABTC-70	70	-	48 Pin TSOP	
MX29LV320ATTI-70	70	-	48 Pin TSOP	
MX29LV320ABTI-70	70	-	48 Pin TSOP	
MX29LV320ATTC-90	90	-	48 Pin TSOP	
MX29LV320ABTC-90	90	-	48 Pin TSOP	
MX29LV320ATTI-90	90	-	48 Pin TSOP	
MX29LV320ABTI-90	90	-	48 Pin TSOP	
MX29LV320ATXBC-70	70	0.8mm/0.3mm	48-Ball CSP	
MX29LV320ABXBC-70	70	0.8mm/0.3mm	48-Ball CSP	
MX29LV320ATXEC-70	70	0.8mm/0.4mm	48-Ball CSP	
MX29LV320ABXEC-70	70	0.8mm/0.4mm	48-Ball CSP	
MX29LV320ATXBI-70	70	0.8mm/0.3mm	48-Ball CSP	
MX29LV320ABXBI-70	70	0.8mm/0.3mm	48-Ball CSP	
MX29LV320ATXEI-70	70	0.8mm/0.4mm	48-Ball CSP	
MX29LV320ABXEI-70	70	0.8mm/0.4mm	48-Ball CSP	
MX29LV320ATXBC-90	90	0.8mm/0.3mm	48-Ball CSP	
MX29LV320ABXBC-90	90	0.8mm/0.3mm	48-Ball CSP	
MX29LV320ATXEC-90	90	0.8mm/0.4mm	48-Ball CSP	
MX29LV320ABXEC-90	90	0.8mm/0.4mm	48-Ball CSP	
MX29LV320ATXBI-90	90	0.8mm/0.3mm	48-Ball CSP	
MX29LV320ABXBI-90	90	0.8mm/0.3mm	48-Ball CSP	
MX29LV320ATXEI-90	90	0.8mm/0.4mm	48-Ball CSP	
MX29LV320ABXEI-90	90	0.8mm/0.4mm	48-Ball CSP	



MX29LV320AT/B

PART NO.	ACCESS TIME (ns)	Ball Pitch/ Ball Size	PACKAGE	Remark
MX29LV320ATTC-70G	70	-	48 Pin TSOP	Pb-free
MX29LV320ABTC-70G	70	-	48 Pin TSOP	Pb-free
MX29LV320ATTI-70G	70	-	48 Pin TSOP	Pb-free
MX29LV320ABTI-70G	70	-	48 Pin TSOP	Pb-free
MX29LV320ATTC-90G	90	-	48 Pin TSOP	Pb-free
MX29LV320ABTC-90G	90	-	48 Pin TSOP	Pb-free
MX29LV320ATTI-90G	90	-	48 Pin TSOP	Pb-free
MX29LV320ABTI-90G	90	-	48 Pin TSOP	Pb-free
MX29LV320ATXBC-70G	70	0.8mm/0.3mm	48-Ball CSP	Pb-free
MX29LV320ABXBC-70G	70	0.8mm/0.3mm	48-Ball CSP	Pb-free
MX29LV320ATXEC-70G	70	0.8mm/0.4mm	48-Ball CSP	Pb-free
MX29LV320ABXEC-70G	70	0.8mm/0.4mm	48-Ball CSP	Pb-free
MX29LV320ATXBI-70G	70	0.8mm/0.3mm	48-Ball CSP	Pb-free
MX29LV320ABXBI-70G	70	0.8mm/0.3mm	48-Ball CSP	Pb-free
MX29LV320ATXEI-70G	70	0.8mm/0.4mm	48-Ball CSP	Pb-free
MX29LV320ABXEI-70G	70	0.8mm/0.4mm	48-Ball CSP	Pb-free
MX29LV320ATXBC-90G	90	0.8mm/0.3mm	48-Ball CSP	Pb-free
MX29LV320ABXBC-90G	90	0.8mm/0.3mm	48-Ball CSP	Pb-free
MX29LV320ATXEC-90G	90	0.8mm/0.4mm	48-Ball CSP	Pb-free
MX29LV320ABXEC-90G	90	0.8mm/0.4mm	48-Ball CSP	Pb-free
MX29LV320ATXBI-90G	90	0.8mm/0.3mm	48-Ball CSP	Pb-free
MX29LV320ABXBI-90G	90	0.8mm/0.3mm	48-Ball CSP	Pb-free
MX29LV320ATXEI-90G	90	0.8mm/0.4mm	48-Ball CSP	Pb-free
MX29LV320ABXEI-90G	90	0.8mm/0.4mm	48-Ball CSP	Pb-free

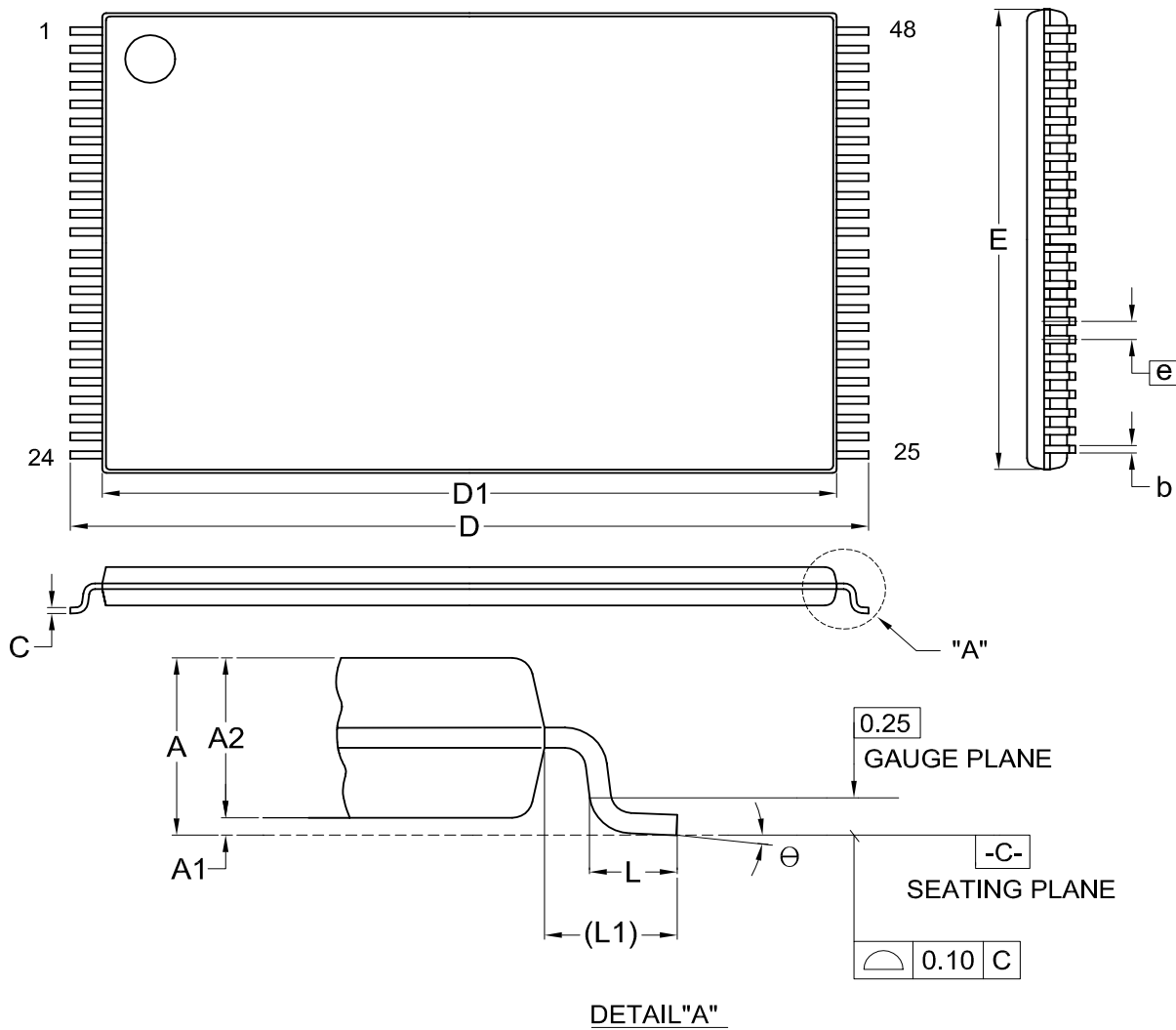
PACKAGE INFORMATION
Title: Package Outline for TSOP(I) 48L (12X20mm)NORMAL FORM

Dimensions (inch dimensions are derived from the original mm dimensions)

SYMBOL		A	A1	A2	b	C	D	D1	E	e	L	L1	θ
mm	Min.	---	0.05	0.95	0.17	0.10	19.80	18.30	11.90		0.50	0.70	0
	Nom.	---	0.10	1.00	0.20	0.13	20.00	18.40	12.00	0.50	0.60	0.80	5
	Max.	1.20	0.15	1.05	0.27	0.21	20.20	18.50	12.10		0.70	0.90	8
Inch	Min.	---	0.002	0.037	0.007	0.004	0.780	0.720	0.469		0.020	0.028	0
	Nom.	---	0.004	0.039	0.008	0.005	0.787	0.724	0.472	0.020	0.024	0.031	5
	Max.	0.047	0.006	0.041	0.011	0.008	0.795	0.728	0.476		0.028	0.035	8

DWG.NO.	REVISION	REFERENCE			ISSUE DATE
		JEDEC	EIAJ		
6110-1607	7	MO-142			12-01-'03

Title: Package Outline for CSP 48BALL(6X8X1.2MM,BALL PITCH 0.8MM,BALL DIAMETER 0.3MM)

TOP VIEW

BOTTOM VIEW

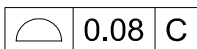
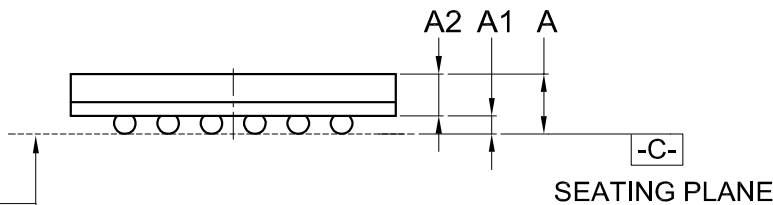
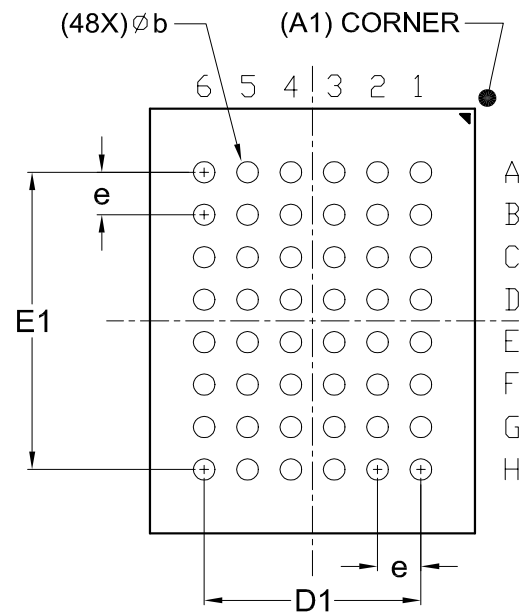
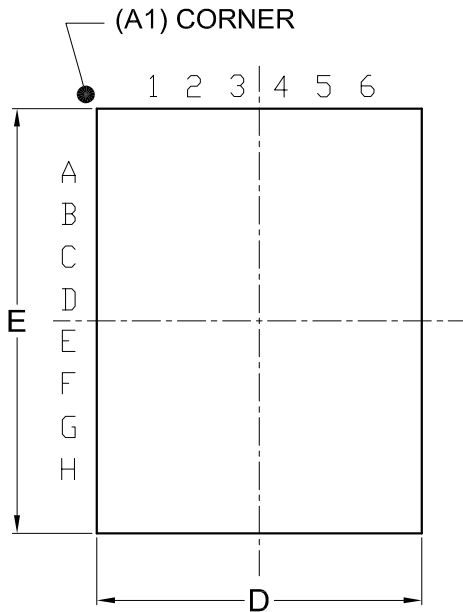

Dimensions (inch dimensions are derived from the original mm dimensions)

SYMBOL		A	A1	A2	b	D	D1	E	E1	e
mm	Min.	---	0.18	0.65	0.27	5.90		7.90		
	Nom.	---	0.23	---	0.30	6.00	4.00	8.00	5.60	0.80
	Max.	1.20	0.28	---	0.37	6.10		8.10		
Inch	Min.	---	0.007	0.026	0.011	0.232		0.311		
	Nom.	---	0.009	---	0.012	0.236	0.157	0.315	0.220	0.031
	Max.	0.047	0.011	---	0.015	0.240		0.319		

DWG.NO.	REVISION	REFERENCE			ISSUE DATE
		JEDEC	EIAJ		
6110-4201	4	MO-210			12-12-'03

Title: Package Outline for CSP 48BALL(6X8X1.3MM,BALL PITCH 0.8MM,BALL DIAMETER 0.4MM)

TOP VIEW

BOTTOM VIEW

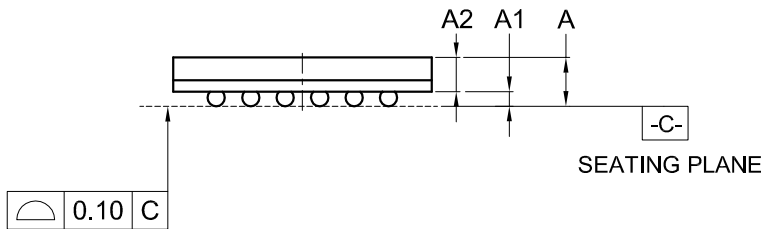
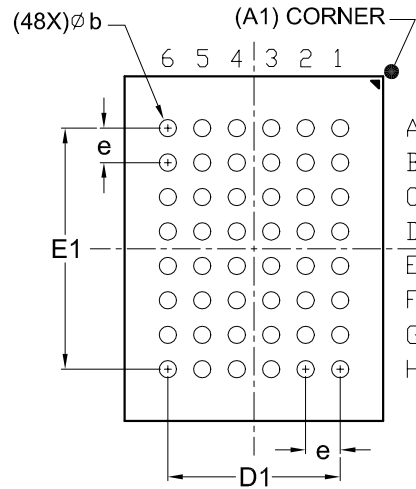
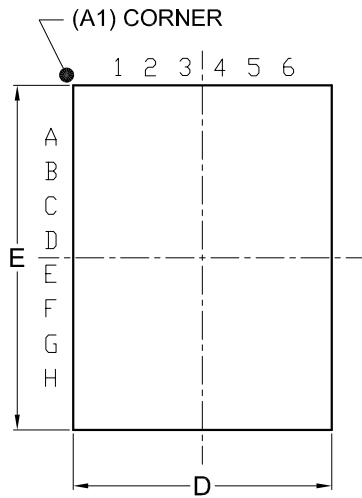

Dimensions (inch dimensions are derived from the original mm dimensions)

SYMBOL		A	A1	A2	b	D	D1	E	E1	e
mm	Min.	---	0.25	0.65	0.35	5.90		7.90		
	Nom.	---	0.30	---	0.40	6.00	4.00	8.00	5.60	0.80
	Max.	1.30	0.35	---	0.45	6.10		8.10		
Inch	Min.	—	0.010	0.026	0.014	0.232		0.311		
	Nom.	—	0.012	—	0.016	0.236	0.157	0.315	0.220	0.031
	Max.	0.051	0.014	—	0.018	0.240		0.319		

DWG.NO.	REVISION	REFERENCE			ISSUE DATE
		JEDEC	EIAJ		
6110-4202	4	MO-219			12-12-'03



REVISION HISTORY

Revision No.	Description	Page	Date
1.0	1. Removed "Advanced Information" on page 1	P1	JAN/30/2004
1.1	1. To removed data retention information	P53	MAY/28/2004



MX29LV320AT/B

MACRONIX INTERNATIONAL Co., LTD.

Headquarters:

TEL:+886-3-578-6688

FAX:+886-3-563-2888

Europe Office :

TEL:+32-2-456-8020

FAX:+32-2-456-8021

Hong Kong Office :

TEL:+86-755-834-335-79

FAX:+86-755-834-380-78

Japan Office :

Kawasaki Office :

TEL:+81-44-246-9100

FAX:+81-44-246-9105

Osaka Office :

TEL:+81-6-4807-5460

FAX:+81-6-4807-5461

Singapore Office :

TEL:+65-6346-5505

FAX:+65-6348-8096

Taipei Office :

TEL:+886-2-2509-3300

FAX:+886-2-2509-2200

MACRONIX AMERICA, INC.

TEL:+1-408-262-8887

FAX:+1-408-262-8810

<http://www.macronix.com>
